



National Défense
Defence nationale

B-GL-372-005/FP-001

OPERATION DOCUMENTATION

35 mm TWIN GUN GDF 005 DRILL BOOK (ENGLISH)

(This publication becomes active on receipt.)

WARNING

ALTHOUGH NOT CLASSIFIED, THIS PUBLICATION, OR ANY PART OF IT, MAY BE EXEMPT FROM DISCLOSURE TO THE PUBLIC UNDER THE ACCESS TO INFORMATION ACT. ALL ELEMENTS OF INFORMATION CONTAINED HEREIN MUST BE CLOSELY SCRUTINIZED TO ASCERTAIN WHETHER OR NOT THE PUBLICATION OR ANY PART OF IT MAY BE RELEASED.

Issued on the authority of the Chief of the Land Staff

Canada



National Défense
Defence nationale

B-GL-372-005/FP-001

OPERATION DOCUMENTATION

35 mm TWIN GUN GDF 005 DRILL BOOK (ENGLISH)

(This publication becomes active on receipt.)

WARNING

ALTHOUGH NOT CLASSIFIED, THIS PUBLICATION, OR ANY PART OF IT, MAY BE EXEMPT FROM DISCLOSURE TO THE PUBLIC UNDER THE ACCESS TO INFORMATION ACT. ALL ELEMENTS OF INFORMATION CONTAINED HEREIN MUST BE CLOSELY SCRUTINIZED TO ASCERTAIN WHETHER OR NOT THE PUBLICATION OR ANY PART OF IT MAY BE RELEASED.

Issued on the authority of the Chief of the Land Staff

OPI: DAD 7-3

2000-06-30

Canada

FOREWORD

1. B-GL-372-005/FP-001 *35 mm Twin Gun GDF 005 Drill Book* is issued on the authority of the Chief of the Land Staff. B-GL-372-005/FP-001 *35 mm Twin Gun GDF 005 Drill Book* is effective upon receipt.
2. The French version of this publication is B-GL-372-005/FP-002, *École de la pièce du canon bitube GDF 005 de 35 mm*.
3. Suggested amendments should be forwarded through normal channels to DLAEEM 3.
4. Unless otherwise noted, masculine pronouns contained herein refer to both genders.

© DND/MDN 2000

PREFACE

1. This drill book is the operator's handbook. Thus, it does not contain a complete description of the 35 mm Twin Gun GDF 005. After completion of the operator's course, it is intended as a guide book to be used by operators in carrying out their duties.
2. The parts of this manual follow a standard sequence, i.e., proceed from point 1 to the last point, page for page, to complete all tasks necessary for correct gun operation. Part 2 is of central importance. It details drills which must always be carried out. The drills detailed in all other parts are only to be carried out on orders from the Detachment Commander.
3. The Detachment Commander has the authority to interrupt a procedure or change the sequences. All checks are the responsibility of the Detachment Commander and will be carried out on his order.
4. The detachment Second in Command is responsible for the initial defence of the gun emplacement. He works under the command of the Detachment Commander.
5. Command and reports are written in capital letters enclosed with quotation marks, e.g., "ATTENTION ALIGNMENT CHECK." Hardware lettering is written in capital letters, e.g., CONVEYOR MOTOR switch is ON, etc
6. Danger, warnings and the exercise of caution are indicated by symbols which appear in front of the text to which they refer.
7. To avoid accidents or damage to equipment during Twin Gun GDF 005 operation and maintenance, always **verify** that the gun is **unloaded** and observe the following safety rules:

SECTION 1 GENERAL

CAUTION

1. **Do not** move the Twin Gun unless the drawbar has been unlocked.
2. **Do not** tow away the gun until the retaining clips on the hand brake levers have been secured.
3. **Do not** move the gun unless the front and rear suspension are locked.
4. **Do not** move the gun manually unless the rear hand brakes and the drawbar are manned.
5. **Do not** use a prime mover that has not been approved for use in moving the gun.
6. **Do not** tow away the gun unless the brakes and the vehicle lighting have been tested.
7. **Do not** back up the gun with a prime mover.
8. **Do not** drive over cables.
9. **Do not** lower levelling jacks on top of cables.
10. **Do not** leave the Power Supply Unit (PSU) in the upper or lower positions unless the safety pin has been inserted in the PSU positioning mount locking lever.
11. **Do not** unhitch the drawbar unless the vehicle lighting cable and brake couplings have been disconnected.

DANGER

1. **Do not** attempt to jack up the gun unless the swivel arms are fully deployed and locked.
2. **Do not** operate the PSU unless the covering hood is in place.
3. **Do not** move barrels unless PSU is in the lowered position.
4. **Do not** operate periscope wiper in dry weather or when the Video Presentation Unit (VPU) is installed.
5. **Do not** engage the manual traverse drive unless the PSU is in the lower position and the barrel support has been folded down.
6. **Do not** operate a gun unless the separating distance to a neighbouring gun is at least 20 metres.
7. **Do not** overload the automatic loader when the gun is in horizontal load position. Excess clips will fall from the automatic loader at high gun elevation angles.
8. **Do not** leave the crank handle on the automatic reloader after use.

WARNING

1. **Do not** leave a stationary gun unattended on its wheels unless all four hand brakes have been applied and the wheel chocks have been inserted.
2. **Do not** take up position on the sides of the gun trailer (i.e., between the wheels or between a wheel and the chassis) while the gun is being moved.
3. **Do not** work alone on the gun.
4. **Do not** work on the gun unless the fire extinguisher has been removed from the gun and placed in a safe and readily accessible location.
5. **Do not** open the caps on the battery cells while the PSU is running.
6. **Do not** refuel PSU except with refuelling system. Manual refuelling is permitted only in case of an emergency.
7. **Do not** place fuel cans near the PSU exhaust pipe.
8. **Do not** operate the gun unless the 10 metre diameter safety fence has been installed.
9. **Do not** approach within the safety zone of the gun when the traverse lock is not engaged.
10. **Do not** engage the elevation or traverse drives unless it has been verified that nobody is within the movement zone of the barrels.
11. **Do not** step on the wheels of a gun in levelled firing position unless the wheels have been locked.
12. **Do not** sit on the automatic reloaders unless the instructor's seat has been installed.

WARNING

1. **Do not** store or mix dummy rounds with live ammunition.
2. **Do not** initiate the quick test unless the NORMAL/TEST lever on the laser transmitter is set to TEST.
3. **Do not** fire the gun unless the hand ratchet has been removed after manual ammunition feeding.
4. **Do not** participate in gun firing without wearing ear protectors.
5. **Do not** fire a gun unless the front cover of the cradle is closed and the receivers are locked.

WARNING—MAINTENANCE

1. **Do not** connect or disconnect the power cables under voltage.
2. **Do not** open compartments containing electrical components unless the PSU or external power source has been switched off.
3. **Do not** remove electrostatic sensitive components unless the appropriate safety measures have been taken.
4. **Do not** work on the gun in a lightning storm.
5. **Do not** attempt to perform maintenance of the gun unless all live ammunition has been removed.

DANGER

1. **Do not** perform the functional check unless all live ammunition has been removed from the gun.
2. **Do not** attempt to tow the gun unless the brake release lever is in the FULL LOAD position.
3. **Do not** place hands inside the automatic loader conveyor drive mechanism during operation unless electrical power has been interrupted and the spring motor tension has been released.
4. **Do not** climb on or off the gun unless the traverse lock is ENGAGED.
5. **Do not** attempt to remove the barrels or parts of the weapon unless the cradle lock has been engaged.
6. **Do not** attempt to clear stoppages or perform automatic loader maintenance unless the conveyor motor has been switched off and the spring motor tension has been released.
7. **Do not** release the breech block after firing unless the weapons have been cocked, the cartridge chamber checked and the barrels have been aimed into the firing zone.
8. **Do not** open the weapon cover or attempt to perform corrective action for at least 20 minutes if a misfire is suspected to have occurred. A misfired round may remain in the chamber.

DANGER—LASER

1. The laser rangefinder operates with an invisible beam that is dangerous to the eyes.
2. The laser safety range is 2400 metres and applies to the naked eye only. When binoculars or a telescope are used to observe the gun emplacement, the safety range must be increased by the magnifying factor of the optics.
3. **Do not** operate the gun in peace time unless the laser safety plate is set to BLUE.
4. **Do not** direct the laser towards people, animals and/or passing objects.
5. **Do not** remain within the safety range without safety goggles when the laser is operating.
6. **Do not** operate the laser unless the laser safety sector has been programmed.
7. **Do not** use binoculars, telescopes or optical magnification aids to observe a target that is being lasered.
8. **Do not** look at the periscope window when tracking is in progress.

FIRST AID—ELECTRIC SHOCK

1. Switch off PSU before touching victim.
2. Remove victim from the danger zone.
3. Immediately call for medical help.
4. Start artificial respiration without delay and continue until medical help arrives.

TABLE OF CONTENTS

FOREWORD i

PREFACE iii

SECTION 1 GENERAL iv

CHAPTER 1 GENERAL

SECTION 1 INFORMATION FOR TRANSPORT OPERATION 1

SECTION 2 GUN DETACHMENT POSITIONS..... 5

 Detachment Front 5

 Detachment Rear 5

 Detachment Mounted in Vehicle 6

 Detachment Front 7

 Detachment Rear 7

SECTION 3 GUN CONFIGURATION DURING OPERATION 9

SECTION 4 REMOTE CONTROLLED OPERATION..... 10

SECTION 5 DUTIES OF GUN DETACHMENT..... 10

SECTION 6 FORM DETACHMENTS FRONT (OR REAR) . 14

SECTION 7 TELL OFF 14

SECTION 8 CHANGE ROUND 14

SECTION 9 SAFETY 15

 Laser 15

 Trigger 16

 Servo Sector/Fire Sector/Laser Sector/ Limited Zone 17

 Personnel Safety 18

 Travelling 18

 Firing 19

 Misfire/Stoppage Safety Procedure 19

CHAPTER 2 STANDARD OPERATING PROCEDURES

SECTION 1 GUN PREPARATION 21

SECTION 2 GUN PREPARATION..... 23

- Halt—Prepare for Action..... 23
- Halt—Action Action Action..... 26
- Readiness Check..... 29
- Virify Servo Sector [Menu 10] and Training Simulator 2 Mod [Menu 23] Settings 32
- Drift Trim [Menu 1] 33
- Set Gun Alignment [Menu 2] 33
- Set Fixed Points and Loading Position [Menu 2] 36
- Set Laser Sector [Menu 3] 37
- Set Fire Sector [Menu 4] 38
- Check Alignment [Menu 2] 39
- Check Fixed Points and Loading Position [Menu 2] 40
- Check Laser Sector [Menu 3] 41
- Check Fire Sector [Menu 4] 42
- Set Distances [Menu 5] 43
- Enter Firing Data [Menu 6] 45
- Enter Meteorological Data [Menu 7]..... 46
- Quick Test [Menu 8] 47
- Error Messages [Menu 9] 48
- Alarm Sectors 48
- Fire Trigger Check 50
- Loading..... 51
- Loading: Initialise Ammunition Account 52
- Unload 53
- Standby 56

SECTION 3 GUN/FIRE UNIT INTEGRATION 57

- Introduction 57

Communication, PSU Run Up and Data	
Transmission Check	58
Direct Orientation.....	59
Indirect Orientation.....	61
Alignment Check.....	63
Zero Test.....	64
Fictitious Target Firing.....	65
SECTION 4 TARGET ENGAGEMENT.....	67
Introduction	67
Local Engagement with Laser Rangefinder.....	67
Local Engagement with Fixed Distance	68
Local Take Over/Remote Acquisition.....	68
Local Take Over/Autonomous Acquisition.....	70
Local Engagement Air Targets.....	71
Local Engagement Ground Targets	73
Automatic Reloading/Refill Reloaders.....	75
Update Ammunition Account.....	76
SECTION 5 AFTER ENGAGEMENT.....	77
Introduction	77
Prepare to Move	77
Cease Firing.....	78
SECTION 6 AUXILIARY OPERATION MODE.....	81
Introduction	81
Halt—Action Manual	81
Readiness Check—Manual.....	83
Fire Trigger Check—Manual	85
Loading—Manual.....	86
Standby—Manual.....	87
Powered with Manual Drive.....	88

Firing with Laser	89
Firing with Fixed Distance	90
Firing Without Power	90
Reloading—Manual	91
Cease Firing—Manual.....	92
SECTION 7 QUICK ACTION	94
Introduction	94
Quick Action, Electrically Supported.....	94
Manual Quick Action	96
SECTION 8 PREPARE GUN FOR TRAINING SIMULATOR 2.....	98
CHAPTER 3 RANGE OPERATIONS	
SECTION 1 RANGE FIRING.....	101
Introduction	101
Systematic Sequence for Preparation of the Fire Unit.....	102
SECTION 2 DUTIES OF NUMBER 1.....	103
Before Firing	103
During Firing.....	103
SECTION 3 DUTIES OF WEAPON SAFETY OFFICER/LASER SAFETY SUPERVISOR	104
Before Firing	104
During Firing.....	105
After Firing.....	105
Fire Control and Select System	106
Communication and Intercom System.....	106
Video Evaluation System	107
SECTION 4 SAFETY SECTORS	107
Laser Sector.....	107
Fire Sector	107

Servo Sector.....	107
Safety Sectors	108
Set Laser Sector	108
Set Fire Sector	110
Set Servo Sector.....	112
Check Laser Sector.....	114
Check Fire Sector	116
Check Servo Sector	118
Laser/Safety Check.....	120
Fire Trigger/Safety Check	124

CHAPTER 4 MAINTENANCE AND CARE

SECTION 1 CRADLE LOCKING PROCEDURE.....	131
SECTION 2 STRIPPING SEQUENCE	133
35 mm Gun	133
Breech Block	134
Trigger Mechanism.....	135
SECTION 3 GUN OPERATION CHECKS	135
Introduction	135
Gun Operation Check	136
Mechanical Trigger and Automatic Loader Check.....	138
Electrical Trigger, Automatic Loader and Reloader Check.....	140
Sight Alignment Check.....	142
SECTION 4 FAULT-FINDING/TROUBLE SHOOTING....	145
Faults on the Gun.....	145
Electrical Faults on the Gun	145
Lamp TROUBLE is Illuminated.....	145
Lamp TROUBLE is Flashing During Normal Operation....	146
Lamp TROUBLE is Flashing After Quick Test (Menu 8) ..	147

B-GL-372-005/FP-001

Gun Error Codes..... 149

Power Supply Unit Error Codes 155

Misfires/Stoppages Electrical 158

Misfires/Stoppages Mechanical..... 161

SECTION 5 PREVENTIVE MAINTENANCE 161

Introduction 161

Materials Check..... 162

LIST OF ABBREVIATIONS 163

LIST OF FIGURES

Figure 1-1: Transport Position 2

Figure 1-2: Ground Clearance..... 2

Figure 1-3: Turning Diameter 3

Figure 1-4: Maximum Side Slope 3

Figure 1-5: Operating Position..... 4

Figure 1-6: Detachment Front (Gun in Tow) 5

Figure 1-7: Detachment Rear (Gun in Tow) 6

Figure 1-8: Detachment Mounted in Prime Mover 7

Figure 1-9: Detachment Front (Gun Autonomous)..... 7

Figure 1-10: Detachment Rear (Gun Autonomous) 8

Figure 1-11: Firing Configuration (Gun in Reloading Position)..... 9

Figure 1-12: Static Mission Deployment 10

Figure 2-1: Gun Data Sheet..... 22

Figure 2-2: Gun Alignment..... 33

Figure 2-3: Alarm Sectors..... 49

Figure 2-4: Direct Orientation..... 59

Figure 2-5: Indirect Orientation 61

Figure 3-1: Systematic Sequence for Preparation of the
Fire Unit 102

Figure 3-2: Fire, Laser and Servo Sectors..... 108

CHAPTER 1
GENERAL

1. This part of B-GL-372-005/FP-001 *35 mm Twin Gun GDF 005 Drill Book* contains information regarding transport and operation of the 35 mm Twin Gun GDF 005, the layout of a Gun Detachment and the duties of the Gun personnel.

SECTION 1
INFORMATION FOR TRANSPORT OPERATION

2. Maximum Allowance Towing Speeds for Twin Gun:
 - a. Highway:
 - (1) 8 Ton or greater Tractor—80 km/h; and
 - (2) less than 8 Tons Tractor—50 km/h.
 - b. Secondary Roads (Any Tractor)—50 km/h.
 - c. Off Road (Any Tractor)—15 km/h.
3. Weight:
 - a. Twin Gun with Power Supply Unit—7760 kg; and
 - b. Power Supply Unit only—600 kg.
4. All pertinent gun dimensions are shown in Figures 1-1 and 1-2. The turning diameter and the maximum permissible side slope are shown in Figures 1-3 and 1-4, respectively. The limiting dimensions for the operating positions are given in Figure 1-5.

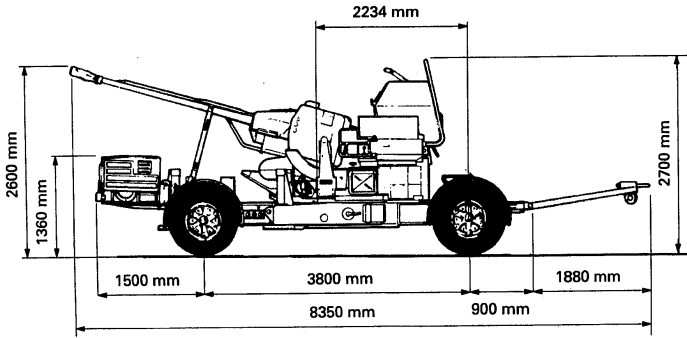

Figure 1-1: Transport Position

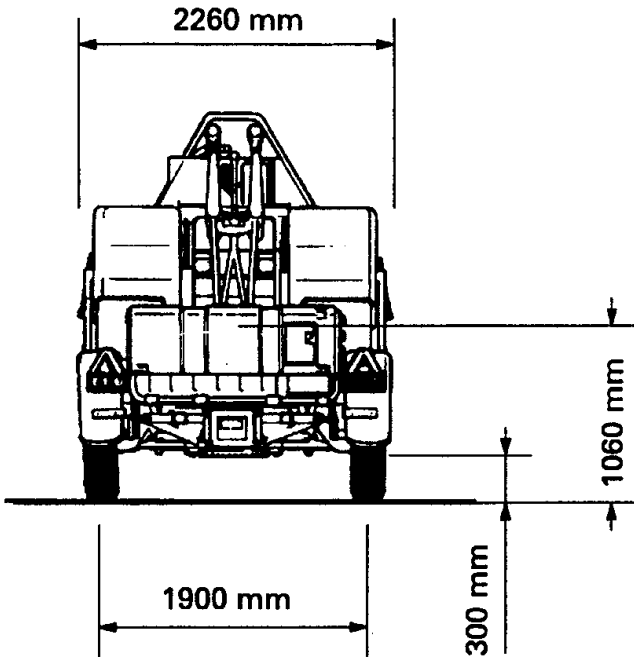

Figure 1-2: Ground Clearance

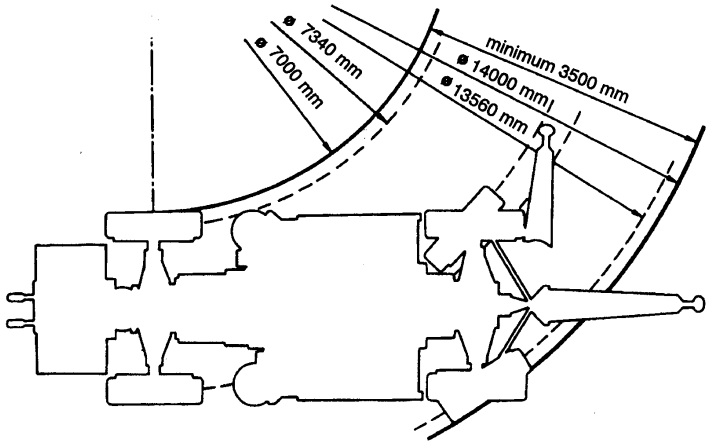

Figure 1-3: Turning Diameter

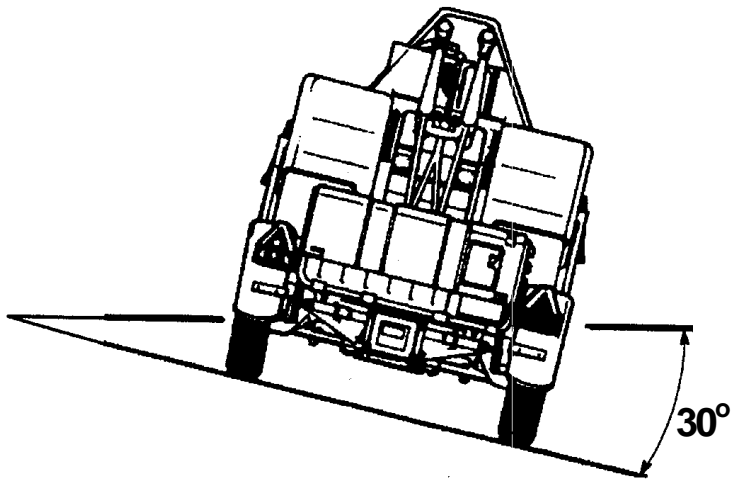

Figure 1-4: Maximum Side Slope

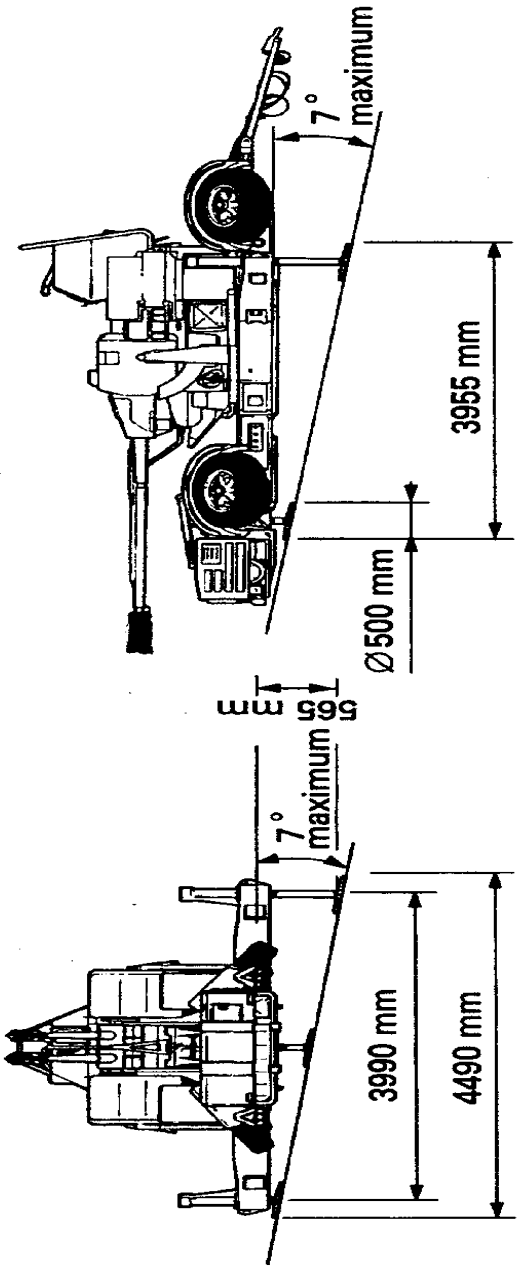

Figure 1-5: Operating Position

SECTION 2 GUN DETACHMENT POSITIONS

DETACHMENT FRONT

5. Gun Detachment positions for Detachment at front as illustrated in Figure 1-6 are as follows:

- a. #1 Detachment Commander;
- b. #2 Operator;
- c. #3 Operator;
- d. #4 Driver; and
- e. #5 Detachment Second in Command.

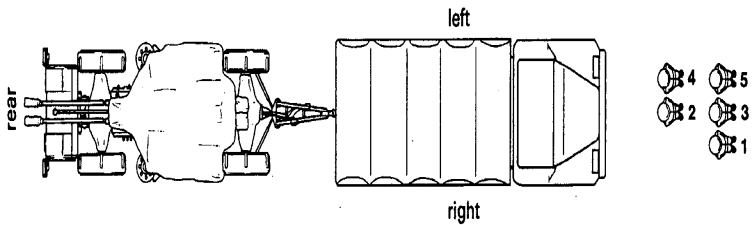

Figure 1-6: Detachment Front (Gun in Tow)

DETACHMENT REAR

6. Gun Detachment positions for Detachment at rear with gun in tow as illustrated in Figure 1-7 are as follows:

- a. #1 Detachment Commander;
- b. #2 Operator;

- c. #3 Operator;
- d. #4 Driver; and
- e. #5 Detachment Second in Command.

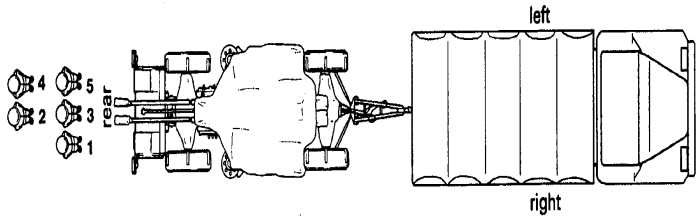

Figure 1-7: Detachment Rear (Gun in Tow)

DETACHMENT MOUNTED IN VEHICLE

7. Gun Detachment positions for Detachment mounted in vehicle as illustrated in Figure 1-8 are as follows:

- a. #1 Detachment Commander;
- b. #2 Operator;
- c. #3 Operator;
- d. #4 Driver; and
- e. #5 Detachment Second in Command.

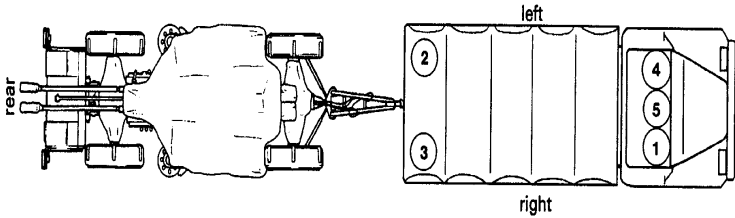

Figure 1-8: Detachment Mounted in Prime Mover

DETACHMENT FRONT

8. Gun Detachment positions for Detachment at front when gun is autonomous as illustrated in Figure 1-9 are as follows:

- a. #1 Detachment Commander;
- b. #2 Operator;
- c. #3 Operator;
- d. #4 Driver; and
- e. #5 Detachment Second in Command.

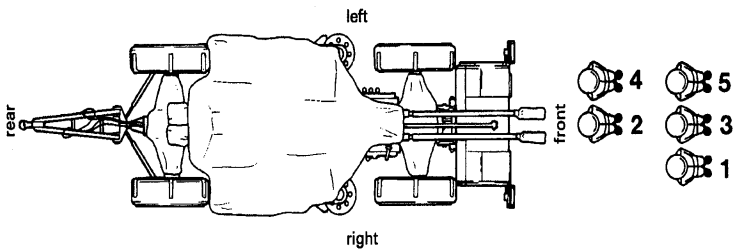

Figure 1-9: Detachment Front (Gun Autonomous)

DETACHMENT REAR

9. Gun Detachment positions for Detachment at rear when gun is autonomous as illustrated in Figure 1-10 are as follows:

35 mm Twin Gun GDF 005 Drill Book

- a. #1 Detachment Commander;
- b. #2 Operator;
- c. #3 Operator;
- d. #4 Driver; and
- e. #5 Detachment Second in Command.

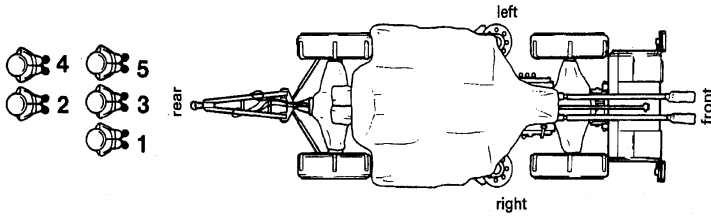
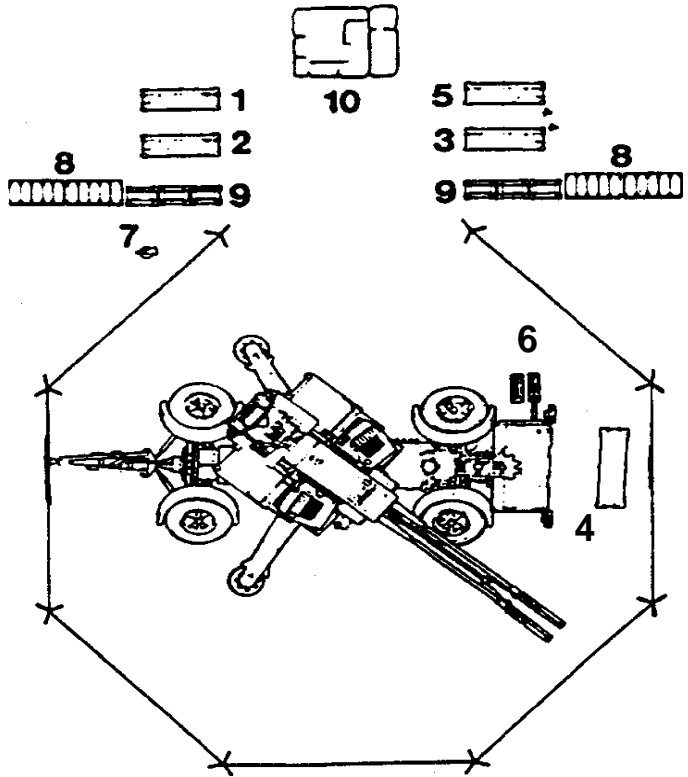

Figure 1-10: Detachment Rear (Gun Autonomous)

SECTION 3
GUN CONFIGURATION DURING OPERATION



- | | | | |
|---|----------------------------|----|-----------------------|
| 1 | Accessories Case | 6 | Fuel Cans |
| 2 | Maintenance Equipment Case | 7 | Fire Extinguisher |
| 3 | Weapon Spare Parts Case | 8 | Ammunition Cases |
| 4 | MV Measuring Base Case | 9 | Ammunition Clip Cases |
| 5 | Exhaust Hose Case | 10 | Covers |

Figure 1-11: Firing Configuration (Gun in Reloading Position)

SECTION 4 REMOTE CONTROLLED OPERATION

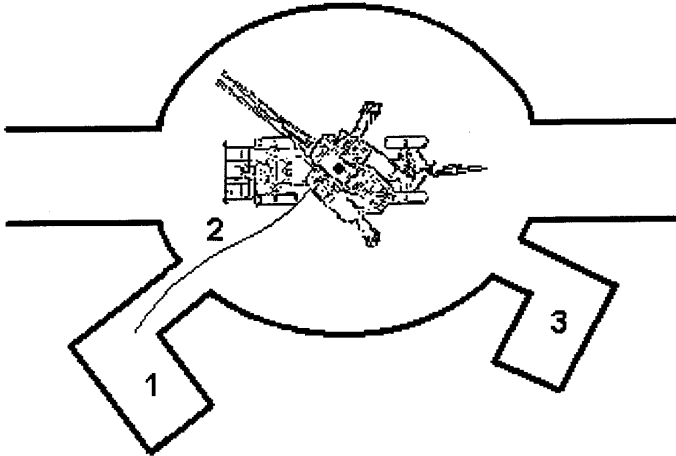

- 1 Gun detachment under cover
- 2 Remote control unit outside safety zone, connected to connector box (gun trailer) via 20 m cable
- 3 Ammunition under cover

Figure 1-12: Static Mission Deployment

SECTION 5 DUTIES OF GUN DETACHMENT

10. **No 1—Detachment Commander:**
 - a. Commands the gun detachment during maintenance and operation of the gun.
 - b. Supervises platform and position.
 - c. Prepares the gun for firing and travelling.
 - d. Carries out sector limitation.
 - e. Carries out functional checks.

- f. Operates Gun King sight.
- g. Aligns the gun.
- h. Checks readiness for action.
- i. Engages targets according to orders.
- j. Ensures that ammunition and detachment reports are made.
- k. Is responsible for power supply unit (PSU) and gun history books.
- l. Reports faults and failure identification (FID) numbers to maintenance personnel.
- m. Checks vehicle lighting and brakes on the gun.
- n. Implements local defence plan under direction of fire unit (FU) Commander.
- o. Ensures that maintenance and technical checks according to Preventive Maintenance Schedule (refer to C-79-214-000/NY-001, Part 1) are performed.

11. **No 2—Operator:**

- a. Prepares the gun for firing and travelling.
- b. Cocks right weapon.
- c. Loads and unload right weapon.
- d. Controls cable drums.
- e. Manually operates right Automatic Loader (AL).
- f. Loads right automatic reloader.
- g. Maintains right weapon.

- h. Carries out gun maintenance.
- i. Keeps PSU supplied with fuel.
- j. Operates Gun King sight as required.
- k. Carries out local defence.

12. **No 3—Operator:**

- a. Prepares the gun for firing and travelling.
- b. Cocks left weapon.
- c. Loads and unloads left weapon.
- d. Rolls out field cables to FCU.
- e. Manually operates left AL.
- f. Loads left automatic reloader.
- g. Maintains left weapon.
- h. Carries out gun maintenance.
- i. Is responsible for data collection.
- j. Drives vehicle as required.
- k. Carries out local defence.
- l. Unloads vehicle.
- m. Prepares ammunition.
- n. Operates Gun King sight as required.
- o. Loads vehicle.
- p. Keeps PSU supplied with fuel.

13. **No 4—Driver:**
 - a. Drives prime mover.
 - b. Carries out local defence.
 - c. Unloads prime mover.
 - d. Prepares ammunition.
 - e. Camouflage prime mover.
 - f. Loads vehicle.
 - g. Carries out vehicle maintenance.
 - h. Prepares the gun for firing and travelling as required.
 - i. Loads and unloads left weapon as required.
 - j. Manually operates left AL.
 - k. Maintains left weapon.
 - l. Carries out gun maintenance.

14. **No 5—Detachment Second in Command (2IC):**
 - a. Detaches gun from prime mover.
 - b. Unloads gun boxes.
 - c. Directs prime mover to shelter.
 - d. Organizes local defence.
 - e. Organizes ammunition and fuel supply.
 - f. Attaches gun to prime mover.
 - g. Loads prime mover.

- h. Replaces No 1 as required.
- i. Operates laser/trigger interrupter.

SECTION 6 FORM DETACHMENTS FRONT (OR REAR)

15. On the order "DETACHMENT FRONT (or REAR)" the detachment falls into two ranks, No 1, No 3 and No 5 from right to left in the front rank: No 2 and No 4 in the rear covering off No 3 and No 5 respectively, with one space between ranks.
16. Dress right and stand at ease (see Figure 1-7).

SECTION 7 TELL OFF

17. On the order "TELL OFF" the Detachment Commander numbers himself "ONE", the man on the right of the rear rank numbers himself "TWO", his front man "THREE" and so on.

SECTION 8 CHANGE ROUND

18. On the order "CHANGE ROUND" No 1 takes one pace to the rear and one pace to the left.
19. No 3 and No 5 take two short paces to the right.
20. No 2 take's two short paces to the left.
21. No 4 take's two short paces to the front.

SECTION 9 SAFETY

LASER

22. The laser safety plate on the connector box must always be set to BLUE. This ensures that the laser circuit is interrupted.
23. The laser enable switch must be connected to the connector box or to the trigger enable jumper, which is connected to the connector box. This allows No 2 to "arm" the laser, thus allowing No 1 to activate it.
24. The headrest contains a limit switch, which must be depressed before the laser will operate.
25. The laser may be actuated:
 - a. when engaging a target by using the tracking button on the control yoke; and
 - b. when engaging a target manually by using the laser/trigger foot switch.

NOTE

The use of the trigger enable jumper and the laser enable switch is a peacetime requirement. In combat situations the plate will be turned to RED.

DANGER

1. The laser beam can cause serious damage to the human eye.
2. Wear laser protective glasses when the laser source is switched to ON!

WARNING

When activated, the laser enable switch bypasses the fire laser safety switch in the connector box.

26. The following safety distances must be observed:

LASER ABSORPTION FILTER	SAFETY DISTANCE AT DIVERGENCE	
	3 mil NORMAL	1 mil NARROW
0	800 m	2400 m
20 dB	75 m	200 m

TRIGGER

27. The following applies to the use of the electrical trigger:

- a. The laser safety plate on the connector box must always be visible on BLUE. This ensures that the trigger circuit is interrupted.
- b. The trigger enable jumper must be connected to the connector box. This allows the trigger to be armed.
- c. Covering the trigger switch on the remote control unit interrupts the trigger circuit.
- d. The trigger circuit is also interrupted by some switches on the control panel.
- e. The trigger will only operate when the gun is pointing within the fire sector and electrical trigger safety conditions are met.

WARNING

The trigger enable jumper bypasses the fire laser safety switch in the connector box. It provides a continuous enable to the firing circuit.

NOTE

The use of the trigger enable jumper and the laser enable switch is a peacetime requirement. In combat situations the plate will be turned to RED.

**SERVO SECTOR/FIRE SECTOR/LASER SECTOR/
LIMITED ZONE**

28. The servo sector prevents the gun servos from **moving** the gun outside the limits entered by the operator for the servo section.
29. The fire sector prevents the gun from **firing** outside the limits entered by the operator for the fire sector.
30. The laser sector prevents laser emission outside the limits entered by the operator for the laser sector.
31. A safety fence is erected around the gun, approximately 30 cm larger in radius than the gun radius with muzzle velocity (MV) bases attached. This marks the limited zone around the gun where no one but the gun operator should be while he has control of the gun in the electrical mode.

NOTE

Personnel can only enter the limited zone in the circumstances specifically defined in the procedures.

PERSONNEL SAFETY

32. All members of the detachment:
 - a. must wear the correct protective clothing;
 - b. must wear ear protectors during firing; and
 - c. must not wear items of clothing, jewellery, watches, etc. that could catch in mechanical parts.
33. No 1 is responsible for the safety of all the members of his detachment.
34. No 5 must ensure that no one is in a danger area before pressing the laser/trigger interrupter.
35. Only climb on or off the gun if the traverse lock is engaged.
36. Within this drill book, all commands written in capitals and enclosed in quotation marks must be given as spoken orders. The detachment must react accordingly and acknowledge them upon completion.
37. Each member of the detachment should carry a copy of this drill book when working with the gun. The drills must be followed precisely as written.
38. Only one person can be on the gun, seated in the operator's seat, at any one time during gun operation. If an instructor's seat is fitted, a second person may be strapped into this seat.

TRAVELLING

39. Never drive over the cables.
40. Always make sure that the stop cock lever is in the FULL LOAD (braked) position.
41. Free the tow bar before travelling.
42. Do not drive in reverse with the gun attached.

43. Make sure that the front and rear undercarriages are locked.
44. Verify that the swivel arm lock is engaged in the catch and that the safety rope is attached.
45. Do not stand between the wheels when moving the gun.

FIRING

46. Make sure that the tow bar is secured and the parking and hand brakes are applied.
47. Ensure that the front and rear undercarriages are locked.
48. Ensure that the stop cock lever is at FULL LOAD.
49. Before levelling the gun ensure that the swivel arms are locked.
50. When manual loading has been completed always remove the hand ratchet.
51. After unloading, cock the weapons, check the cartridge chamber and raise the barrels into the firing zone before releasing the breech block.
52. If the automatic loader jams, release tension in the spring motor drive before putting hands inside the loader.

MISFIRE/STOPPAGE SAFETY PROCEDURE

53. If a weapon does not fire after the trigger has been actuated and the breech block released, and firing has taken place within the last 20 minutes, the following procedure shall be carried out:
 - a. the gun operator brings the gun to the loading position;
 - b. reports misfire to the Weapon Safety Officer;
 - c. sets FIRE SWITCH to SAFE (covered);

35 mm Twin Gun GDF 005 Drill Book

- d. sets POWER switch to OFF;
- e. sets CONVEYOR MOTOR switch on the technical panel to OFF;
- f. engages traverse lock;
- g. places the yellow flag on the cabin cross bar; and
- h. the detachment then evacuates the gun site for a period of 20 minutes before taking any further measures.

54. This procedure must also be carried out if a weapon stops firing unexpectedly.

CHAPTER 2

STANDARD OPERATING PROCEDURES

SECTION 1

GUN PREPARATION

1. This part of B-GL-372-005/FP-001 *35 mm Twin Gun GDF 005 Drill Book* deals with bringing the gun to such a state that it is able to engage targets autonomously.
2. The procedures can be suspended on No 1's command, while other procedures take place (e.g., fire unit [FU] orientation) once a Menu is completed.
3. If any faults occur (e.g., TROUBLE lamp blinking or on) while preparing for engagement, proceed with Part 4.2, Faultfinding Procedures.
4. The alignment of the gun described in this part is done with an aiming circle operated by the FCU operator. However, if no aiming circle is available, alignment can also be carried out with a compass or on a distant reference point, provided that the angle to the north can be read off an accurate map.
5. The following is an example of a data sheet that could be used to collect all necessary data:

FIRE SECTOR PT 1 _____ PT 2 _____ PT 3 _____ PT 4 _____
 PT 5 _____ PT 6 _____ PT 7 _____ PT 8 _____
 LASER SECTOR PT 1 _____ PT 2 _____ PT 3 _____ PT 4 _____
 PT 5 _____ PT 6 _____ PT 7 _____ PT 8 _____
 LASER LONG _____ SHORT _____
 SERVO SECTOR left _____ right _____ high _____ low _____
 SALVO TIME _____ Sec. INITIAL VELOCITY _____ m/s
 BALLISTIC NO 1 _____ BALLISTIC GROUP NO _____
 AIR TEMP _____ °c AIR PRESSURE _____ mbar
 WIND SPEED _____ m/s WIND DIRECTION _____ mil
 DATE CHECKED _____ TIME _____

Figure 2-1: Gun Data Sheet

**SECTION 2
GUN PREPARATION**

6. Prepare for Action is normally carried out under cover, close to the next position the FU will occupy.
7. The purpose is to prepare the gun for rapid deployment and to eliminate any defects or faults.
8. During Prepare for Action, the gun is left hooked to the prime mover.
9. If so ordered, the power supply unit (PSU) may be left lowered and operating.
10. The detachment should report all faults and errors to No 1.

HALT—PREPARE FOR ACTION

No 1	No 2	No 3	No 4	No 5
"HALT PREPARE FOR ACTION" Insert pump handle Pump twice Remove locking pin Pull stop lever back Move slide lever down PSU is lowered Engage stop lever	Dismount Roll up air outlet flap	Dismount	Prepare ammunition (in vehicle) Prepare MV bases Install refuelling device Place stores on vehicle	Prepare ammunition (in vehicle) Prepare MV bases Install refuelling device Place stores in vehicle

35 mm Twin Gun GDF 005 Drill Book

No 1	No 2	No 3	No 4	No 5
Re-insert locking pin				
Replace pump lever	Remove PSU cover	Remove PSU cover		
Check on control panel:				
PSU main switch at OFF	Check oil level	Check cable connections on connector box		
INSTALL switch at NORMAL	Check coolant level			
GEN switch ON at	Check PSU condition visually	Replace PSU cover		
Circuit breaker F2 in	Replace PSU cover			
Circuit breaker F3 in				

No 1	PSU Display
Set battery switch to ON	0
Actuate the switch DSPL Test (Display Test) and check display	8 8 8 8
Actuate FUEL switch and check contents	1 1 1 1 - 0 0 0 0
Set PSU main switch to STANDBY	A
Wait until B appears	B
Press START button	C1
Wait until C2 appears	C2
Set PSU main switch to OPERATION	

No 1	No 2/Right	No 3/Left
Unfasten main tarpaulin at rear and remove	Unfasten main tarpaulin at front and remove	Unfasten main tarpaulin at front and remove
Remove sight tarpaulin	Unfasten rear undercarriage tarpaulin	Unfasten rear undercarriage tarpaulin
Release elevation brake	Remove reloader tarpaulin	Remove reloader tarpaulin
Unlock barrel support and lower	Remove automatic loader (AL) tarpaulin	Remove AL tarpaulin
Remove barrel tarpaulin	Remove front undercarriage tarpaulin	Remove front undercarriage tarpaulin
	Remove muzzle brake and replace with MV base	Remove muzzle brake and replace with MV base
	Move reloader to SP (service position)	Move reloader to SP
	Check grease level control button on Automatic Lubrication System (ALs)	
	Cock weapon and release tension	Cock weapon and release tension
	Ensure empty cartridge clip is in loader	Ensure empty cartridge clip is in loader
	Set discharge lever to IM	Set discharge lever to IM
Clamp barrels	Load reloader	Load reloader
Raise PSU	Move reloader to WP (waiting position)	Move reloader to WP

No 1	No 2/Right	No 3/Left
"DETACHMENT REAR, REPORT" "MOUNT"	Report all faults to No 1	Report all faults to No 1

HALT—ACTION ACTION ACTION

NOTE

The gun should be brought to the gun marker and the trailer oriented so that the PSU exhaust points towards the direction of threat. If time permits, No 1 should order the detachment to lay out the lower camouflage nets and extend the upper camouflage nets.

No 1	No 2	No 3	No 4	No 5
Guide vehicle to gun marker "HALT ACTION ACTION ACTION"	Dismount	Dismount		Dismount
	Insert wheel chock			
	Apply rear hand brake	Apply rear hand brake		
	Disconnect brake hose yellow and lighting cable	Disconnect brake hose red and removes safety pin		
	Assist unhooking tow bar	Assist unhooking tow bar		
"DRIVE ON—HALT" (approximately 5 m)			Drive on—halt	
	Secure tow bar (red pin)	Secure tow bar (red pin)	Unload stores	Unload stores
Lower PSU (if it was raised)				

No 1	No 2	No 3	No 4	No 5
<p>Unlock barrels and lower</p> <p>Set INSTALL switch to LVL ONLY</p> <p>Raise gun "UNLOCK WHEELS"</p> <p>Unlock wheel rear left</p> <p>Tilt wheels "LOCK WHEELS"</p> <p>Lock wheel left rear</p> <p>Lower and level gun</p>	<p>Check reloader is in WP</p> <p>Swing out swivel arm locks it in firing position Remove upper camouflage tarpaulin</p> <p>Unlock wheel rear right "UNLOCKED"</p> <p>Lock wheel right rear "LOCK WHEELS"</p>	<p>Check reloader is in WP</p> <p>Swing out swivel arm locks it in firing position Remove fire extinguisher Remove upper camouflage tarpaulin</p> <p>Unlock wheels front "UNLOCKED"</p> <p>Lock wheels front "LOCK WHEELS"</p>	<p>Place stores according to operation configuration (see Figure 1-11)</p>	<p>Place stores according to operation configuration (see Figure 1-11)</p>

35 mm Twin Gun GDF 005 Drill Book

No 1	No 2	No 3	No 4	No 5
<p>INSTALL switch NORMAL</p> <p>Inspect safety fence</p> <p>Perform Readiness Check</p>	<p>Set up safety fence (if required)</p> <p>Check safety fence manually rotate the barrels in traverse</p> <p>Control cable drums</p>	<p>Set up safety fence (if required)</p> <p>Check safety fence Adjust fence posts</p> <p>Reel out cable drums to FCU</p> <p>Carry gun marker to FCU</p> <p>Give data and intercom lines to FCU operators</p>	<p>Move vehicle to cover</p> <p>Camouflage and maintain</p>	

READINESS CHECK

No 1	No 2	No 3
<p>"READINESS CHECK"</p> <p>Move left reloader to SP (service position). Ensure empty cartridge clip is in AL</p> <p>Press circuit breaker in left support arm</p> <p>Verify parallelogram at required position</p> <p>Move left reloader to WP</p> <p>Ensure FAST/SLOW lever is set on SLOW</p> <p>Check PSU for fuel content and errors</p> <p>Ensure barrel clamp is fully home in firing position</p> <p>Check data cable connection comms:</p> <p>Panel plate blue, activate all 12 circuit breakers and CONNECTS trigger enable jumper box</p> <p>Move right reloader to SP</p> <p>Ensure empty cartridge clip is in AL</p> <p>press circuit breaker in right support arm</p> <p>verify parallelogram at required position</p> <p>Move right reloader to WP</p> <p>Ensure all control panel switches are up (ON) position except AMMUNITION switch, which should be set to REST 3</p>	<p>Prepare ammunition</p>	<p>Prepare ammunition</p>

35 mm Twin Gun GDF 005 Drill Book

No 1	No 2	No 3
<p>Ensure that the 4 circuit breakers are pressed</p> <p>Adjust seat</p> <p>Mount reflector and plug-in headset</p> <p>Set MOTOR/HAND (azimuth) lever to MOTOR</p> <p>Ensure manual crank (azimuth) is out of the way</p> <p>TRIGGER switch on remote control unit is covered</p> <p>Set POWER switch to OFF</p> <p>Set NORMAL/NARROW switch to NORMAL</p> <p>Set NORMAL/TEST switch to NORMAL</p> <p>Remove front sight cover</p> <p>Engage collimator</p> <p>Set MOTOR/HAND (elevation) lever to MOTOR</p> <p>Ensure manual crank (elevation) is out of the way</p> <p>Ensure FIRE/SAFE lever is on SAFE</p> <p>Ensure that gas shield is up</p> <p>Set WIPER switch to OFF</p> <p>Set RANGE switch to LASER</p> <p>Set LOCAL/REMOTE switch to LOCAL</p>		

No 1	
Set POWER switch to ON (TROUBLE lamp is flashing)	
GUN KING Program No	Appears briefly
CODER NOT CALIB	
Actuate LAMP TEST switch and check lamps on remote control unit	
Ensure that no one is inside the limited zone	
"DISENGAGED"	
Disengage traverse lock	WARNING Gun will move for about two seconds
Set POWER switch to SERVO	
MENU 1	
Check that only the READY lamp is ON (if not go to Menu 9)	
Remove eyepiece cover	
Adjust crosshair focus	
Adjust head rest	
Adjust illumination of reticule with ILLUM knob	
"READY" to FCU	

No 1	No 2 and 3
Set POWER switch to ON	
Engage traverse lock	
"ENGAGED"	Connect field cables
Ensure no one is inside limited zone	
Disengage traverse lock	
"DISENGAGED"	
Set POWER switch to SERVO	

VERIFY SERVO SECTOR [MENU 10] AND TRAINING SIMULATOR 2 MODE [MENU 23] SETTINGS

No 1	
MENU 10	Ensure that Menu 10 is selected.
RET	
SECT LIM MOUNT = 0	
If SEC LIM MOUNT = 1 enter 0	
RET	
MENU 1	
NOTE	
To set the servo sector refer to Section 3.1.11.	
MENU 23	Ensure that Menu 23 is selected.
RET	
TRAINING MODE = 0	
If TRAINING_MODE = 1 enter 0	
RET	
MENU 1	

DRIFT TRIM [MENU 1]

No 1	
CAUTION	
Do not touch the control yoke before or when Menu 1 is running	
<div style="border: 1px solid black; padding: 5px; display: inline-block;">MENU 1</div>	Ensure Menu 1 is selected
<div style="background-color: black; color: white; padding: 5px; display: inline-block; margin: 0 auto;">RET</div>	
<div style="border: 1px solid black; padding: 5px; display: inline-block;">DRIFT TRIM</div>	Drift trim program runs automatically
<div style="border: 1px solid black; padding: 5px; display: inline-block;">MENU 2</div>	

SET GUN ALIGNMENT [MENU 2]

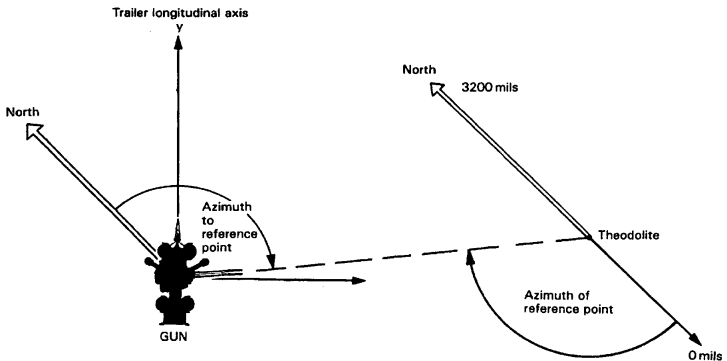

Figure 2-2: Gun Alignment

No 1	Aiming circle Operator
<div data-bbox="238 196 456 256" style="border: 1px solid black; padding: 2px; margin-bottom: 10px;"> ORIENT 1002 MIL </div> <div data-bbox="298 272 385 305" style="background-color: black; color: white; text-align: center; padding: 2px; margin-bottom: 10px;"> RET </div> <div data-bbox="238 321 456 358" style="border: 1px solid black; padding: 2px;"> FIX1 CHECK? </div>	
<p>NOTE</p> <p>During night deployment, No 1 will send No 2 to the Aiming circle to receive angle to north.</p>	

SET FIXED POINTS AND LOADING POSITION [MENU 2]

No 1	
RET	
FIX1 PROC?	
YES	
FIX1 PROC -> RET	
Sight on FCU position	
RET	
FIX2 CHECK?	
RET	
Select terrain point (no more than 4 km away)	
FIX2 PROC?	
YES	
FIX2 PROC -> RET	
Sight exactly on the terrain point	
RET	
LOAD PROC?	
YES	
LOAD PROC -> RET	
Traverse gun to loading position	
RET	
MENU 3	

SET LASER SECTOR [MENU 3]

NOTE	
<ol style="list-style-type: none"> 1. Laser sector limits: <ol style="list-style-type: none"> a. No laser sector limitation—choose 3 points in the direction of each levelling jack with the barrels at maximum depression, or b. Terrain limitation, or c. Laser window 	
No 1	
<div style="border: 1px solid black; display: inline-block; padding: 2px 10px;">MENU 3</div>	Ensure that Menu 3 is selected.
<div style="background-color: black; color: white; display: inline-block; padding: 2px 10px;">RET</div>	
<div style="border: 1px solid black; display: inline-block; padding: 2px 10px;">LSECT CHECK?</div>	
<div style="background-color: black; color: white; display: inline-block; padding: 2px 10px;">RET</div>	
<div style="border: 1px solid black; display: inline-block; padding: 2px 10px;">LSECT PROC?</div>	
<div style="background-color: black; color: white; display: inline-block; padding: 2px 10px;">YES</div>	
<div style="border: 1px solid black; display: inline-block; padding: 2px 10px;">Azimuth Elevation 1</div>	Current position is displayed.
Sight on sector point No 1	
<div style="border: 1px solid black; display: inline-block; padding: 2px 10px;">Azimuth Elevation 1</div>	
<div style="background-color: black; color: white; display: inline-block; padding: 2px 10px;">RET</div>	
Sight on sector point No 2	
<div style="border: 1px solid black; display: inline-block; padding: 2px 10px;">Azimuth Elevation 2</div>	The angle between points must not exceed 3200 mils.
<div style="background-color: black; color: white; display: inline-block; padding: 2px 10px;">RET</div>	
Sight on sector point No 3	
<div style="border: 1px solid black; display: inline-block; padding: 2px 10px;">Azimuth Elevation 3</div>	

No 1	
RET	Repeat procedure for desired number of points (minimum 3, maximum 20).
END	Leave Menu when required points have been selected. The last point stored is automatically linked to the first.

SET FIRE SECTOR [MENU 4]

NOTE	
1. Fire sector limits:	
a.	No fire sector limitation—choose 3 points in the direction of each levelling jack with the barrels at maximum depression, or
b.	Terrain limitation, or
c.	Firing window

No 1	
MENU 4	Ensure that Menu 4 is selected.
RET	
FSECT CHECK?	
RET	
FSECT PROC?	
YES	
Azimuth Elevation 1	Current position is displayed.
Sight on sector point No 1	
Azimuth Elevation 1	
RET	

No 1	
Sight on sector point No 2	
<input type="text" value="Azimuth Elevation 2"/>	The angle between points must not exceed 3200 mils.
<input type="button" value="RET"/>	
Sight on sector point No 3	
<input type="text" value="Azimuth Elevation 3"/>	
<input type="button" value="RET"/>	Repeat procedure for desired number of points (minimum 3, maximum 20). Leave Menu when required points have been selected. The last point stored is automatically linked to the first.
<input type="button" value="END"/>	

CHECK ALIGNMENT [MENU 2]

No. 1	
Set both MOTOR/HAND levers to MOTOR	
Set POWER switch to SERVO	
<input type="text" value="MENU 2"/>	Select Menu 2
<input type="button" value="RET"/>	
<input type="text" value="ALIG CHECK?"/>	
<input type="button" value="YES"/>	
<input type="text" value="ORIENT MIL"/>	
Check correctness of stored point	

WARNING
Gun will move to stored point.

No 1	
<p style="text-align: center;">Check correctness of FCU position</p> <p style="text-align: center;">RET</p> <div style="border: 1px solid black; width: 150px; margin: 5px auto; text-align: center; padding: 2px;">FIX2 PROC?</div> <p style="text-align: center;">RET</p> <div style="border: 1px solid black; width: 150px; margin: 5px auto; text-align: center; padding: 2px;">LOAD PROC?</div> <p style="text-align: center;">RET</p> <div style="border: 1px solid black; width: 150px; margin: 5px auto; text-align: center; padding: 2px;">MENU 3</div>	
<div style="text-align: right; background-color: #e0e0e0; padding: 10px; border: 1px solid black;"> <p style="margin: 0;">WARNING</p> <p style="margin: 0;">Gun will move to loading position.</p> </div>	
<p>Press LOAD POS button.</p>	

CHECK LASER SECTOR [MENU 3]

No 1	
<div style="border: 1px solid black; width: 150px; margin: 5px auto; text-align: center; padding: 2px;">MENU 3</div> <p style="text-align: center;">RET</p> <div style="border: 1px solid black; width: 150px; margin: 5px auto; text-align: center; padding: 2px;">LSECT CHECK?</div>	<p>Ensure that Menu 3 is selected.</p>
<p style="text-align: center;">YES</p> <div style="border: 1px solid black; width: 150px; margin: 5px auto; text-align: center; padding: 2px;">Azimuth Elevation 1</div> <p>Check position of sector point No 1</p>	<div style="text-align: right; background-color: #e0e0e0; padding: 10px; border: 1px solid black;"> <p style="margin: 0;">WARNING</p> <p style="margin: 0;">Gun will move to laser sector point 1.</p> </div>
<p style="text-align: center;">RET</p>	<div style="text-align: right; background-color: #e0e0e0; padding: 10px; border: 1px solid black;"> <p style="margin: 0;">WARNING</p> <p style="margin: 0;">Gun will move to laser point 2.</p> </div>

No 1	
Azimuth Elevation 2	Continue with this procedure until sector point No 1 is displayed again.
END	
Leave Menu 3 when all points have been checked.	
MENU 4	

CHECK FIRE SECTOR [MENU 4]

No 1	
MENU 4	Ensure that Menu 4 is selected.
RET	
FSECT CHECK?	
	WARNING Gun will move to fire sector point 1.
YES	
Azimuth Elevation 1	
Check position of sector point No 1	
	WARNING Gun will move to fire sector point 2.
RET	
Azimuth Elevation 2	
Continue with this procedure until sector point No 1 is displayed again.	
END	Leave Menu 4 when all points have been checked.
MENU 5	

SET DISTANCES [MENU 5]

NOTE	
<p>This procedure can only be carried out after all the laser safety precautions have been met (refer to section 1.9.1).</p>	
No 1	No 5
<p>"MEASURE RANGE TO FIXED POINT"</p> <p><input type="text" value="MENU 5"/> Ensure that Menu 5 is selected</p> <p style="text-align: center;">RET</p> <p><input type="text" value="CHANGE DATA?"/></p> <p style="text-align: center;">YES</p> <p><input type="text" value="LASER RAN M"/> Last range measured is displayed</p> <p>Sight on fixed point roughly Change MOTOR/HAND levers to HAND Look through periscope and sight on fixed point exactly Lock drive handles Set NORMAL/NARROW switch to NARROW Ensure LASER RANGE switch is set at LASER</p> <p>"READY"</p>	<p>If safety conditions have been met press laser enable switch "LASER FREE"</p>

No 1	No 5
<p>Look through periscope and press head rest Open cover of laser/trigger foot switch Press laser/trigger foot switch briefly</p> <div data-bbox="128 326 386 394" style="border: 1px solid black; padding: 2px;">LASER RAN M</div> <p>Current measured value displayed.</p> <p>Read out measured range Repeat procedure for measurement of additional fixed points "RANGE MEASURING FINISHED" Ensure laser/trigger foot switch is covered Change NORMAL/NARROW switch to NORMAL Change MOTOR/HAND lever to MOTOR Ensure that only READY lamp is ON</p>	<p>Release laser enable switch</p>

No 1
<div data-bbox="131 794 397 833" style="border: 1px solid black; padding: 2px;">LASER RAN M</div> <div data-bbox="205 846 288 881" style="background-color: black; color: white; text-align: center; padding: 2px;">RET</div> <div data-bbox="131 894 397 933" style="border: 1px solid black; padding: 2px;">LONG RAN M</div> <p>Enter range for fixed distance LONG</p> <div data-bbox="205 995 288 1031" style="background-color: black; color: white; text-align: center; padding: 2px;">RET</div> <div data-bbox="131 1044 397 1083" style="border: 1px solid black; padding: 2px;">SHORT RAN M</div> <p>Enter range for fixed distance SHORT</p> <div data-bbox="205 1144 288 1180" style="background-color: black; color: white; text-align: center; padding: 2px;">RET</div> <div data-bbox="128 1193 397 1232" style="border: 1px solid black; padding: 2px;">MENU 6</div>

ENTER FIRING DATA [MENU 6]

No 1	
<div style="border: 1px solid black; padding: 2px; text-align: center; margin-bottom: 5px;">MENU 6</div>	Ensure that Menu 6 is selected
RET	
<div style="border: 1px solid black; padding: 2px; text-align: center; margin-bottom: 5px;">CHANGE DATA?</div>	
YES	
<div style="border: 1px solid black; padding: 2px; text-align: center; margin-bottom: 5px;">SALVOTIM SEC</div>	
Enter required burst duration (range 0.2-2.5 sec)	
RET	
<div style="border: 1px solid black; padding: 2px; text-align: center; margin-bottom: 5px;">BAL NO.</div>	
Enter required ballistic number (1 for normal, 2 for short trajectory, 3 for AHEAD ammunition)	
if 1:	<div style="border: 1px solid black; padding: 2px; text-align: center; margin-bottom: 5px;">BAL_NO 1</div>
RET	
	<div style="border: 1px solid black; padding: 2px; text-align: center; margin-bottom: 5px;">BAL1_GROUP = ..</div>
Set required ballistic group number	1 for target practice (TP-T) ammunition 2 for high explosive incendiary (HEI) ammunition
RET	
<div style="border: 1px solid black; padding: 2px; text-align: center; margin-bottom: 5px;">VO M/S</div>	
Enter initial muzzle velocity (range 750-1350 m/s)	
RET	
<div style="border: 1px solid black; padding: 2px; text-align: center; margin-bottom: 5px;">FIRED L ... RD</div>	
END	
if 2:	<div style="border: 1px solid black; padding: 2px; text-align: center; margin-bottom: 5px;">BAL_NO 2</div>
RET	

No 1	
	<input type="text" value="VO M/S"/> Set initial muzzle velocity (range 750-1350 m/s)
	<input type="button" value="RET"/>
	<input type="text" value="FIRED L ... RD"/>
	<input type="button" value="END"/>
	<input type="text" value="MENU 7"/>
if 3:	<input type="text" value="BAL_NO 3"/>
	<input type="button" value="RET"/>
	<input type="text" value="VO M/S"/> Set initial muzzle velocity (range 750-1350 m/s)
	<input type="button" value="RET"/>
	<input type="text" value="TIME_FIXED = 0"/> If TIME_FIXED = 1 enter a 0
	<input type="button" value="RET"/>
	<input type="text" value="TZ_FIX...MS"/>
	<input type="button" value="END"/>
	<input type="text" value="MENU 7"/>
	"FIRING DATA SET"

ENTER METEOROLOGICAL DATA [MENU 7]

No 1	
<input type="text" value="MENU 7"/>	Ensure that Menu 7 is selected.
<input type="button" value="RET"/>	
<input type="text" value="CHANGE DATA?"/>	
<input type="button" value="YES"/>	

No 1	
<div style="border: 1px solid black; padding: 2px; text-align: center; margin-bottom: 5px;">TEMP .. DEG C</div>	Enter ballistic air temperature (range -40°C +55°C) <div style="background-color: black; color: white; text-align: center; padding: 5px; margin: 5px auto; width: 50px;">RET</div>
<div style="border: 1px solid black; padding: 2px; text-align: center; margin-bottom: 5px;">PRESS ... MBAR</div>	Enter air pressure (range 720-1095 mbar) <div style="background-color: black; color: white; text-align: center; padding: 5px; margin: 5px auto; width: 50px;">RET</div>
<div style="border: 1px solid black; padding: 2px; text-align: center; margin-bottom: 5px;">WINDSPEED .. M/S</div>	Enter wind speed (range 0-40 m/s) <div style="background-color: black; color: white; text-align: center; padding: 5px; margin: 5px auto; width: 50px;">RET</div>
<div style="border: 1px solid black; padding: 2px; text-align: center; margin-bottom: 5px;">WINDDIR ... MIL</div>	Enter wind direction (range 0-6399 mil) <div style="background-color: black; color: white; text-align: center; padding: 5px; margin: 5px auto; width: 50px;">RET</div>

QUICK TEST [MENU 8]

No 1	
WARNING	
Cover the Periscope window for ultimate protection against laser radiation in case of shutter failure prior to activating the Quick Test.	
<div style="border: 1px solid black; padding: 2px; text-align: center; margin-bottom: 5px;">MENU 8</div>	Ensure that Menu 8 is selected. Set NORMAL/TEST switch to TEST <div style="background-color: black; color: white; text-align: center; padding: 5px; margin: 5px auto; width: 50px;">RET</div>
<div style="border: 1px solid black; padding: 2px; text-align: center; margin-bottom: 5px;">TEST ACTIVE</div>	Quickest program runs automatically.
WARNING Gun moves erratically.	

No 1
<div style="border: 1px solid black; padding: 5px; margin: 10px auto; width: 150px; text-align: center;">MENU 9</div> <p>Set NORMAL/TEST switch to NORMAL If TROUBLE lamp is not flashing or on finish Quick Test If TROUBLE is flashing check error codes</p>

ERROR MESSAGES [MENU 9]

No 1
<div style="border: 1px solid black; padding: 5px; margin: 10px auto; width: 150px; text-align: center;">MENU 9</div> Ensure that Menu 9 is selected.
<div style="background-color: black; color: white; padding: 2px 10px; display: inline-block;">RET</div>
<div style="border: 1px solid black; padding: 5px; margin: 10px auto; width: 150px; text-align: center;">NO ERRORS</div> When no errors are present.
<div style="background-color: black; color: white; padding: 2px 10px; display: inline-block;">END</div>
<div style="border: 1px solid black; padding: 5px; margin: 10px auto; width: 150px; text-align: center;">MENU 10</div>
<div style="border: 1px solid black; padding: 5px; margin: 10px auto; width: 150px; text-align: center;">Error Code</div> When errors are present.
<div style="background-color: black; color: white; padding: 2px 10px; display: inline-block;">RET</div>
<div style="background-color: black; color: white; padding: 2px 10px; display: inline-block;">END</div>
Press RET until all error numbers have been read out and written down.
<div style="border: 1px solid black; padding: 5px; margin: 10px auto; width: 150px; text-align: center;">MENU 10</div>

ALARM SECTORS

11. For autonomous firing (without FCU), the Detachment Commander must organize an orientation system for his gun. This system enables observers to designate the target that No 1 has to engage.

- a. Azimuth:
 - (1) Clock system with direction 12 to north or on a reference object.

b. Elevation:

- (1) A low sector up to 200 mil;
- (2) A medium sector from 200 up to 600 mil;
- (3) A high sector over 600 and up to 1600 mil.

12. The Detachment Commander must ensure that the gun detachment understands the orientation system by giving some exercise commands:

a. "EXERCISE—ALARM TWO MEDIUM".

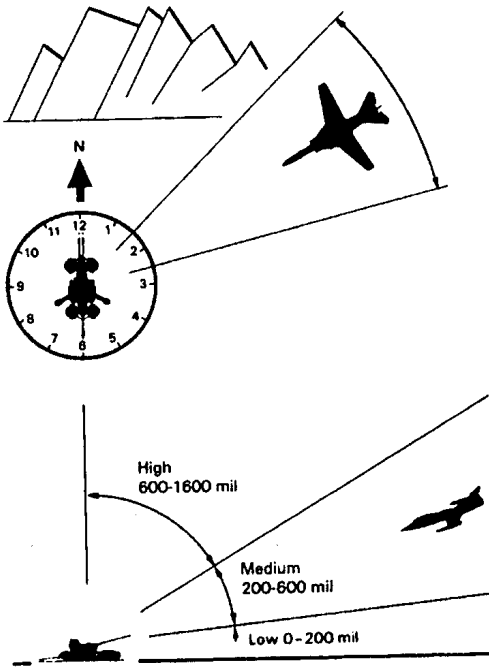

Figure 2-3: Alarm Sectors

FIRE TRIGGER CHECK

<p>NOTE</p> <p>This procedure can only be carried out after all trigger safety precautions have been met. Refer to section 1.9.2.</p> <p>DANGER</p> <p>Make sure the gun is not loaded.</p>	
No 1	No 2
<p>"FIRE TRIGGER CHECK"</p> <p>Ensure that:</p> <p>AMMUNITION switch is at REST 3</p> <p>CONVEYOR MOTOR switch is ON</p> <p>READY lamp is on</p> <p>RANGE switch is at LONG</p> <p>Rotate barrels into fire sector</p> <p>Set TRIGGER switch on control box to ON</p> <p>"FIRING"</p> <p>Press TRACKING button (short alarm tone is audible)</p> <p>Press FIRE SAFETY and FIRE BARS—both triggers released</p> <p>Press TRACKING button twice to return to READY status</p> <p>Continue this procedure to check fire sector (3-4 times)</p> <p>Set TRIGGER switch to OFF</p>	

No 1	No 2
Set RANGE switch to LASER "TRIGGER CHECK FINISHED"	
<p style="text-align: center;">WARNING</p> <p>If no further firing/laser training is to be carried out return the gun to a safe condition by removing laser enable switch and the trigger enable jumper after the fire trigger check and prior to loading.</p>	

LOADING

<p style="text-align: center;">DANGER</p> <ol style="list-style-type: none"> Only feed weapons when ordered. Make sure Firing Maintenance has been carried out (refer to section 3.2). 	
No 1	Nos 2 and 3
<p>"LOADING"</p> <p>Ensure that TRIGGER switch on remote control unit is covered</p> <p>Ensure that mechanical firing lever is on S</p> <p>Ensure that READY lamp is on</p>	<p>Move behind loading position outside safety fence</p>
<p style="text-align: center;">WARNING</p> <p>Gun moves.</p>	
<p>Press LOAD POS button</p> <p>Set POWER switch to ON and back to SERVO</p> <p>Move the barrels approximately horizontally</p> <p>Set POWER switch to ON</p> <p>Engage traverse lock</p> <p>"ENGAGED"</p>	

No 1	
RET	Press RET 7 times.
FIRED PRESET?	
YES	Resets firing counter to 0.
AMM FULL?	
RET	
AMM EMPTY?	
YES	Resets ammunition reserve counter to 0.
AMMO RELO+?MAG	
<p>Enter total number of cartridge clips loaded for both sides Ask FCU permission to feed</p>	

UNLOAD

No 1	Nos 2 and 3
Ensure trigger switch is covered Press LOAD POS button Set POWER switch is ON Engage traverse lock "ENGAGED" Set CONVEYOR MOTOR switch to OFF Set MOTOR/HAND levers to HAND Lower barrels approximately 0 mil and brake elevation drive handle	

No 1	Nos 2 and 3
"UNLOAD"	Move reloaders to SP. Set discharge levers to OA.

DANGER			
The spring motor may still be wound with enough power to operate the feed mechanism at full speed.			
No 1	No 2	No 3	Nos 4 and 5
	Remove full cartridge clips from AL and give to No 4 Set discharge lever at IM Cock weapons and do not release cable Open weapon protective cover	Remove full cartridge clips from AL and give to No 4 Set discharge lever at IM Cock weapon and do not release cable	Place cartridge clips in ammunition boxes
	Open weapon covers completely		
	WARNING		
	Beware of the weapon protective cover overhead		
	Remove rounds lying on feed tray and put them on an empty cartridge clip		
	Close weapon covers and open again		
	Continue procedure until no rounds are left on the feed tray		

No 1	No 2	No 3
<p>Set right CONVEYOR MOTOR switch to ON for approximately 3 seconds</p> <p>Set left CONVEYOR MOTOR switch to ON for approximately 3 seconds</p> <p>Inspect weapons</p> <p>"CANNONS CLEAR"</p> <p>Report CANNONS CLEAR to FCU</p> <p>Set AMMUNITION switches to REST 3</p>	<p>Close weapon cover "FEED RIGHT"</p> <p>Open weapon cover Check that cartridge chamber feed try and AL are free of rounds "NO 2 UNLOADED"</p> <p>Close weapon cover Close weapon protective cover Release cocking cable Put an empty cartridge clip in AL Fetch reloader unloading device Unload reloader</p>	<p>Leave weapon cover open</p> <p>Close weapon cover "FEED LEFT" Open weapon cover Check that cartridge chamber feed tray and AL are free of rounds "NO 3 UNLOADED"</p> <p>Close weapon cover Release cocking cable Put an empty cartridge clip in AL Fetch reloader unloading drive Unload reloader</p>
	<p>Nos 4 and 5 receive the full cartridge clips from Nos 2 and 3 and place them in ammunition boxes.</p>	
	<p>Move reloader to WP</p>	<p>Move reloader to WP</p>

No 1	No 2	No 3
<p>Move barrels into fire sector</p> <p>Set mechanical firing lever to F (fire)</p> <p>"RELEASING THE BREECH BLOCK"</p> <p>Press down laser/trigger foot switch</p> <p>Set mechanical firing lever to S (safe)</p> <p>Note all information in Menu 6</p>	<p>Go outside limited zone</p>	<p>Go outside limited zone</p>

STANDBY

NOTE	
<p>All future work is based on standby, which should be re-established after any mode of operation.</p>	
No 1	Nos 2 and 3
<p>"STANDBY"</p> <p>Indicate standby direction with an extended arm (choose most threatening direction for an air attack)</p> <p>Bring gun barrels to standby direction (elevation approximately 0-200 mil)</p>	<p>Observe standby direction as indicated by No 1</p>

No 1

Ensure that:

POWER switch on SERVO

Select Menu 1

TRIGGER switch on remote control unit is covered (S position)

Mechanical firing lever at S

Laser/trigger foot switch is covered

On control panel all switches up (ON)

NORMAL/NARROW switch at NORMAL

NORMAL/TEST switch at NORMAL

LOCAL/REMOTE switch at LOCAL

WIPER switch is off

RANGE switch is at LASER

Gas shield is up

Only READY lamp is illuminated

If trigger must be on:

Set TRIGGER switch to F (fire), cover is opened

"TRIGGER IS OPEN"

SECTION 3**GUN/FIRE UNIT INTEGRATION****INTRODUCTION**

13. The FCU must compensate for the parallax condition that exists between the FCU and the gun.

14. Computation of the parallax values (lateral displacement, vertical displacement) is carried out by the FCU computer, based on slant range, lateral displacement angles and angle of sight.

"Orientation" consists of determining these values.

15. In the case of visual contact between FCU and gun, the parallax values are measured automatically and the gun is directly orientated.

16. If there is no visual contact between the FCU and the gun, the gun can be orientated indirectly by using the aiming circle.

COMMUNICATION, PSU RUN UP AND DATA TRANSMISSION CHECK

NOTE		
1. Carry out these checks: <ul style="list-style-type: none"> a. At Fire Unit formation b. After a job rotation c. After a detachment change 		
FU Commander	No 1 Gun 1	No 1 Gun 2
Press TALK button before speaking "ATTENTION, COMMUNICATION CHECK" "GUN 1 REPORT" "GUN 2 REPORT" "ATTENTION PSU RUN UP AND DATA TRANSMISSION CHECK" Press ALARM GUN button once "COMMUNICATION CHECKS FINISHED" Press ALARM GUN button twice	Press intercom bar at control yoke when answering "GUN 1 COMMS OK" Set POWER switch to OFF "GUN 1 READY" "GUN 1 OK" Set POWER switch to SERVO	Press intercom bar at control yoke when answering "GUN 2 COMMS OK" Set POWER switch to OFF "GUN 2 READY" "GUN 2 OK" Set POWER switch to SERVO
If a transmission fails, check field wires and circuit breakers		

DIRECT ORIENTATION

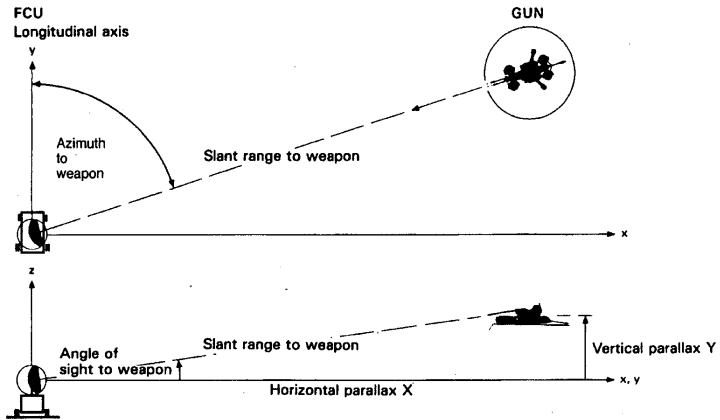

Figure 2-4: Direct Orientation

FU Commander	No 1
<p>"ATTENTION GUN 1 (2)"</p> <p>"DIRECT ORIENTATION"</p>	<p>Report to FU Commander "GUN 1 (2): DIRECT ORIENTATION"</p> <p>Ensure mechanical firing lever and TRIGGER switch are at S</p> <div style="border: 1px solid black; padding: 5px; margin-bottom: 5px; display: flex; justify-content: space-between;"> MENU 2 Select Menu 2 </div> <div style="text-align: center; margin-bottom: 5px;">RET</div> <div style="border: 1px solid black; padding: 5px; margin-bottom: 5px; display: flex; justify-content: space-between;"> ALIG CHECK? </div> <div style="text-align: center; margin-bottom: 5px;">RET</div> <div style="border: 1px solid black; padding: 5px; margin-bottom: 5px; display: flex; justify-content: space-between;"> ALIG PROC? </div> <div style="text-align: center; margin-bottom: 5px;">RET</div> <div style="border: 1px solid black; padding: 5px; margin-bottom: 5px; display: flex; justify-content: space-between;"> FIX1 CHECK? </div>

<p>FU Commander</p>	<p>No 1</p>
<p>"GUN 1 (2): ORIENTATION FINISHED"</p>	<div style="text-align: right; background-color: #e0e0e0; padding: 5px;"> <p>WARNING Gun will move to fix point 1.</p> </div> <p style="text-align: center;">YES</p> <p style="text-align: center;">FIX1 CHECK -> RET</p> <p style="text-align: center;">RET</p> <p style="text-align: center;">FIX1 PROC?</p> <p style="text-align: center;">YES</p> <p style="text-align: center;">FIX1 PROC -> RET</p> <p>Set POWER switch to ON Change MOTOR/HAND levers to HAND Open reflector Look through periscope and sight on white crosshair of FCU TV camera Lock drive handle and check alignment again Report to FCU Commander "GUN 1 (2): ORIENTATION FINISHED"</p> <p>Report to FU Commander "GUN 1 (2): FCU SIGHTED ON"</p> <p style="text-align: center;">RET</p> <p style="text-align: center;">FIX2 CHECK?</p> <p style="text-align: center;">END</p> <p style="text-align: center;">MENU 3</p> <p style="text-align: center;">MENU 1 Select Menu 1</p>

FU Commander	No 1
	Close reflector Change MOTOR/HAND lever to MOTOR Set POWER switch to SERVO Bring gun to standby

INDIRECT ORIENTATION

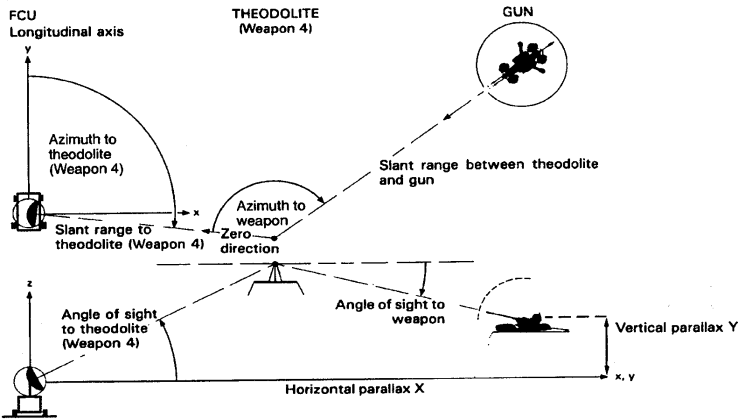

Figure 2-5: Indirect Orientation

FU Commander	No 1	Nos 2 and 3
"ATTENTION GUN 1 (2): INDIRECT ORIENTATION" (FCU carries out alignment with Aiming circle) "ATTENTION GUN 1 (2): SIGHT ON AIMING CIRCLE"	Report to FU Commander "ATTENTION GUN 1 (2): INDIRECT ORIENTATION"	

FU Commander	No 1	Nos 2 and 3
<p>"GUN 1 (2): ORIENTATION FINISHED"</p>	<p>"GUN 1 (2) SIGHT ON AIMING CIRCLE"</p> <p>Ensure mechanical firing lever and TRIGGER switch are at S</p> <div style="border: 1px solid black; padding: 5px; margin: 5px 0; display: inline-block;">MENU 2</div> Select Menu 2	

RET

ALIG CHECK?

RET

ALIG PROC?

RET

FIX1 CHECK?

RET

FIX1 PROC?

YES

FIX1 PROC →
RET

FU Commander	No 1	Nos 2 and 3
<p>"ATTENTION ALIGNMENT CHECK: REFERENCE POINT NO ..."</p>	<p style="text-align: center;">RET</p> <p style="text-align: center;">FIX2 CHECK?</p> <p style="text-align: center;">END</p> <p style="text-align: center;">MENU 3</p> <p style="text-align: center;">MENU 1</p> <p style="text-align: right;">Select Menu 1</p> <p>Set MOTOR/HAND levers to MOTOR</p> <p>Set POWER switch to SERVO</p> <p>Bring gun to standby</p> <p>"GUN 1 (2) ALIGNMENT CHECK: REFERENCE POINT NO ..."</p>	<p>Stay out of limited zone</p>

ALIGNMENT CHECK

FU Commander	No 1	Nos 2 and 3
	<p>When alarm tone sounds once, switch LOCAL/REMOTE switch to REMOTE</p> <p>Look through optical system and estimate how many mils the centre point deviates in traverse and elevation from the reference point</p> <p>Report to FU Commander</p> <p>"DEVIATION GUN 1 (2) AZIMUTH LEFT/RIGHT ... MIL ELEVATION UP/DOWN ... MIL"</p>	

FU Commander	No 1	Nos 2 and 3
<p>"ALIGNMENT CHECK FINISHED"</p>	<p>When alarm tone sounds twice, switch LOCAL/REMOTE switch to LOCAL</p> <p>Report to FU Commander and No's 2 and 3</p> <p>"GUN 1 (2) ALIGNMENT CHECK FINISHED"</p> <p>Brings gun barrels to standby direction</p> <p>Bring gun to previous state of readiness</p>	

ZERO TEST

NOTE		
<p>The zero test is designed as a dynamic orientation check without leading angle calculations.</p>		
FU Commander	No 1	Nos 2 and 3
<p>"ATTENTION GUN 1 (2): ZERO TEST"</p> <p>"REPORT DEVIATION"</p>	<p>"GUN 1 (2) ZERO TEST"</p> <p>When alarm tone sounds once, switch LOCAL/REMOTE switch to REMOTE</p> <p>Look through optical system and estimate how many mil the centre point deviates in traverse and elevation from the target</p> <p>Report to FU Commander (several times at different ranges)</p>	<p>Stay out of limited zone</p>

FU Commander	No 1	Nos 2 and 3
<p>"ZERO TEST FINISHED:</p>	<p>"GUN 1 (2) AZIMUTH LEFT/RIGHT ... MIL; ELEVATION HIGH/LOW ... MIL"</p> <p>When alarm tone sounds twice, switch LOCAL/REMOTE switch to LOCAL</p> <p>"GUN 1 (2) ZERO TEST FINISHED"</p> <p>Bring the gun barrels to standby direction</p>	

FICTITIOUS TARGET FIRING

<p style="text-align: center;">NOTE</p>		
<p>Whenever possible carry out fictitious target firing with live ammunition to ensure the function and accuracy of the complete fire unit. If permission for live firing is not granted, carry out the same procedure to ensure the function of the trigger actuation from the FCU.</p>		
<p style="text-align: center;">FCU Commander</p>	<p style="text-align: center;">No 1</p>	<p style="text-align: center;">Safety Personnel (if applicable)</p>
<p>"ATTENTION GUN 1 (2) PREPARE FOR FICTITIOUS TARGET FIRING"</p> <p>Prepare FCU for fictitious target firing</p>	<p>"GUN 1 (2) FICTITIOUS TARGET FIRING"</p> <p>Set AMMUNITION switch to REST 10</p> <p>Ensure Menu 9 shows no errors</p>	<p>Take post</p>

FCU Commander	No 1	Safety Personnel (if applicable)
"FICTITIOUS TARGET FIRING FINISHED"	Switch LOCAL/REMOTE switch to LOCAL Set TRIGGER switch to S (safe) "GUN 1 (2) FICTITIOUS TARGET FIRING FINISHED"	Prohibit laser and fire from FCSS

SECTION 4 TARGET ENGAGEMENT

INTRODUCTION

17. The salvo time recommended for local firing is 0.5 seconds. For remote controlled firing, the fire duration is controlled by the FCU. The gun is permanently on standby. The FU Commander gives the state of readiness (PSU on STANDBY or OPERATION). Whenever possible, the FCU remotely controls the firing at a target.

LOCAL ENGAGEMENT WITH LASER RANGEFINDER

18. Standby procedures carried out (TRIGGER safety switch open). The short tone on the alarm tone system only sounds if a laser safety condition is not met. This is the normal procedure for target engagement. No 1 engages targets, designated by either the FCU or observers.

LOCAL ENGAGEMENT WITH FIXED DISTANCE

19. Standby procedures carried out (TRIGGER safety switch open). Ground targets can also be engaged with fixed distance SHORT or LONG. This procedure is only used in an emergency when the laser is not operating. No 1 engages targets, designated by either the FCU or observers.

LOCAL TAKE OVER/REMOTE ACQUISITION

20. Whenever "GUN ALARM" from the FCU is given, the gun horn sounds once and the operator switch the LOCAL/REMOTE switch to REMOTE. Remotely controlled firing is not further described in this chapter.

21. Whenever "END OF GUN ALARM" is given, the gun horn sounds twice and the operator switches the LOCAL/ REMOTE switch to LOCAL. The operator must always be ready to take over tracking from the FCU and to fire in local mode with or without the rangefinder.

22. Take Over is only done on the FU Commander's order.

23. Standby procedures carried out (TRIGGER safety switch open). This procedure is normally carried out with the laser rangefinder (also possible with fixed distance).

24. In the case of remotely controlled firing, the after firing procedures stay the same as described in this part.

25. When taking over from the FCU, No 5 is required to press the laser/trigger interrupter when all safety precautions are met.

FU Commander	No 1	Alarm Tone (Sight System)
	Gun horn sounds once TRIGGER switch ON AMMUNITION switch is REST 10	

FU Commander	No 1	Alarm Tone (Sight System)
	Update ammunition account (refer to Section 2.3.6)	

LOCAL TAKE OVER/AUTONOMOUS ACQUISITION

26. In order to engage two targets at the same time, the FU commander defines one of the two guns as AUTONOMOUS.

27. If a target is assigned to the autonomous gun, an alarm tone sounds via the intercom system.

28. By pressing button EXTERNAL ASSIGNMENT, the gun moves to the target direction in azimuth. The target is then acquired by moving the gun in elevation until the target is in sight.

No 1	Alarm Tone (Intercom)	Alarm Tone (Sight System)
TRIGGER switch ON Press EXTERNAL ASSIGNMENT, keep pressed Look through optical system Move gun in elevation with control yoke until target is in sight Release EXTERNAL ASSIGNMENT Check target tracking	CONTINUOUS ALARM TONE NO TONE CONTINUOUS ALARM TONE	

No 5	No 1	Alarm Tone (Sight System)
<p>met</p> <p>"ALARM NEW TARGET – TWO MEDIUM"</p> <p>"ALL CLEAR"</p>	<p>Press TRACKING button briefly</p> <p>Continue smooth tracking (IFF)</p> <p>Press FIRE SAFETY BAR</p> <p>Press FIRE switch and keep FIRE SAFETY BAR pressed</p> <p>Press TRACKING button once to return to tracking mode</p> <p>Press TRACKING button twice to return to rest</p> <p>Acquire target by means of collimator and proceed as described above</p> <p>Press TRACKING button twice to return to reset</p> <p>Close TRIGGER switch</p> <p>Go to standby</p> <p>Update ammunition account (refer to Section 2.3.6)</p>	<p>NO TONE</p> <p>MEDIUM TONE</p> <p>LONG TONE</p> <p>LONG TONE</p> <p>MEDIUM/ LONG TONE</p> <p>NO TONE</p>

LOCAL ENGAGEMENT GROUND TARGETS

No 5	No 1	Alarm Tone (Sight System)
<p>"ATTENTION GROUND TARGETS – FIVE LOW ... (target type)"</p> <p>Press laser/trigger interrupter if safety precautions are met</p> <p>"ALARM NEW TARGET – TWO LOW ... (target type)"</p>	<p>TRIGGER switch ON</p> <p>AMMUNITION switch to REST 10</p> <p>Set NORMAL/NARROW switch to NARROW</p> <p>Acquire target by means of collimator</p> <p>Look through optical system and press headrest</p> <p>Keep target in centre of reticule</p> <p>Press TRACKING button briefly</p> <p>Continue smooth tracking (IFF)</p> <p>Press FIRE SAFETY BAR</p> <p>Press FIRE switch and keep FIRE SAFETY BAR pressed</p> <p>Press TRACKING button once to return to tracking mode</p> <p>Press TRACKING button twice to return to rest</p> <p>Acquire target by means of collimator and proceed as described above</p>	<p>NO TONE</p> <p>MEDIUM TONE</p> <p>LONG TONE</p> <p>LONG TONE</p> <p>MEDIUM/ LONG TONE</p> <p>NO TONE</p>

35 mm Twin Gun GDF 005 Drill Book

No 5	No 1	Alarm Tone (Sight System)
	Press TRACKING button twice to return to reset Set NORMAL/NARROW switch to NORMAL Close TRIGGER switch Go to standby Update ammunition account (refer to Section 2.3.6)	

AUTOMATIC RELOADING/REFILL RELOADERS

NOTE		
<p>No 1 can initiate automatic reloading by pressing the AUTOM LOAD switch on the remote control unit. This procedure is always carried out after firing and before refilling the reloaders.</p>		
No 1	No 2 (right)	No 3 (left)
<p>Ensure that TRIGGER switch is at S</p> <p>Press LOAD POS button</p>		
WARNING		
<p>Gun moves to loading position</p>		
<p>Set the POWER switch to ON and back to SERVO</p> <p>Lower the barrels to approximately 0 mil</p> <p>Set POWER switch to ON</p> <p>Engage the traverse lock</p> <p>"ENGAGED"</p> <p>"REFILL RELOADERS"</p> <p>Note how many cartridge clips were in reloaders</p>	<p>Move reloader to SP</p> <p>Check red grease level button on ALs</p> <p>Refill reloader</p> <p>Move reloader to WP</p>	<p>Move reloader to SP</p> <p>Refill reloader</p> <p>Move reloader to WP</p>

No 1	
<div style="border: 1px solid black; padding: 5px; margin: 10px auto; width: 60%;"> AMMO RELO+?MAG </div> <p style="text-align: center;">Enter number of cartridge clips loaded</p> <div style="display: flex; justify-content: center; align-items: center; margin: 10px auto;"> <div style="background-color: black; color: white; padding: 5px 15px; margin-right: 10px;">RET</div> To store value </div> <div style="border: 1px solid black; padding: 5px; margin: 10px auto; width: 60%;"> AMMO RES ... RD </div> <div style="display: flex; justify-content: center; align-items: center; margin: 10px auto;"> <div style="background-color: black; color: white; padding: 5px 15px; margin-right: 10px;">END</div> </div> <div style="border: 1px solid black; padding: 5px; margin: 10px auto; width: 60%;"> MENU 7 </div> <div style="display: flex; justify-content: center; align-items: center; margin: 10px auto;"> <div style="border: 1px solid black; padding: 5px; margin-right: 10px; width: 60%;"> MENU 1 </div> Select Menu 1 </div>	

SECTION 5 AFTER ENGAGEMENT

INTRODUCTION

NOTE

In certain situations, some elements of this part need not be carried out. These situations are covered in Section 2.6, Quick Action.

29. This part deals with taking the gun out of action.

PREPARE TO MOVE

No 1	No 2	No 3	No 4	No 5
"PREPARE TO MOVE"	Remove lower camouflage net	Remove lower camouflage net		Remove lower camouflage net

35 mm Twin Gun GDF 005 Drill Book

No 1	No 2	No 3	No 4	No 5
Watch arcs	Swing in upper camouflage net and place on tarpaulin	Swing in upper camouflage net and place on tarpaulin		Pack all extra ammunition
NOTE				
This drill can vary depending on the time remaining in action and is also dependant on unit SOPs.				

CEASE FIRING

No 1	No 2	No 3	No 4	No 5
"UNLOAD"	Unload respective side	Unload respective side	Put ammunition in boxes Bring prime mover to position Load all stores on prime mover including refuelling device and fuel cans	Put ammunition in boxes Load all stores on prime mover including refuelling device and fuel cans
"CEASE FIRING" Place barrels over PSU Replace sight cover Set INSTALL switch on PSU to LVL ONLY Switch on hydraulic pump	Reel in cable drum Remove safety fence	Reel in cable drum Remove safety fence		

Standard Operating Procedures

No 1	No 2	No 3	No 4	No 5
Push in FAST/ SLOW lever Lift gun "UNLOCK WHEELS" Unlock wheels Lower wheels "LOCK WHEELS" Lock wheels Lower gun INSTALL switch to NORMAL Replace barrel tarpaulin Raise and lock barrels	Unlock wheels "UNLOCKED" Lock wheels "LOCKED" Swing in swivel arm Remove MV and replace with muzzle brakes Replace front undercarriage tarpaulin	Unlock wheels "UNLOCKED" Lock wheels "LOCKED" Swing in swivel arm Remove MV and replace with muzzle brakes Replace front undercarriage tarpaulin	Replace fire extinguisher	

35 mm Twin Gun GDF 005 Drill Book

No 1	No 2	No 3	No 4	No 5
Replace sight tarpaulin	Replace reloader tarpaulin	Replace reloader tarpaulin		
Lower collimator	Replace AL tarpaulin	Replace AL tarpaulin		
	Replace rear undercarriage tarpaulin	Replace rear undercarriage tarpaulin		
Replace main tarpaulin	Replace main tarpaulin	Replace main tarpaulin		
Guide prime mover to towing hook	Free towbar (red pin)	Free towbar (red pin)	Back prime mover to gun guided by No 1	
	Lift	Lift		
	Hook towbar into towing eye	Hook towbar into towing eye		
Switch off PSU	Hook up brake hose yellow	Hook up brake hose red		
	Hook up vehicle lighting cable			
Raise PSU	Release hand brake	Release hand brake		Ensure stop cock lever is at FULL LOAD
	Replace wheel chock			
Insert pump lever PSU	Roll down air outlet cover			
Lift slide lever				

No 1	No 2	No 3	No 4	No 5
Remove locking pin Disengage rocking lever Pump PSU up Replace locking pin Replace pump lever "MOUNT"				
CHECK Condition of tires Rear hand brakes are unlocked Stop cock lever is at FULL LOAD Towbar is properly connected to the prime mover Brake couplings are properly connected Lighting cable is properly connected Tarpaulins are fitted correctly Swivel arms are retracted and secured				

**SECTION 6
AUXILIARY OPERATION MODE**

INTRODUCTION

30. The auxiliary operation mode allows the gun to be operated without power from the PSU, for example, as a result of a breakdown of the PSU.

HALT—ACTION MANUAL

No 1	Nos 2 and 3
"HALT - ACTION MANUAL" Uncover gun	

35 mm Twin Gun GDF 005 Drill Book

No 1	Nos 2 and 3
<p>Lower PSU Move slide lever down PSU is automatically lowered Lower barrels</p> <p>Push in FAST/SLOW lever Set the three jack control levers to RAISE position</p> <p>Set the three jack control levers to NEUTRAL Unlock front and rear undercarriage locking levers Set wheel control lever to RAISE Ensure undercarriage locks are engaged Set wheel control lever to NEUTRAL "LEVELLING"</p>	<p>Apply park brakes Secure towbar Swing out swivel arms and lock Remove barrel cover Remove muzzle covers Remove protective cover on hand pump Take out hand pump lever Insert hand pump lever</p> <p>Set hand pump selection lever to the chosen jack</p> <p>Lift gun Lift gun until wheels are clear of the ground by raising each jack individually</p> <p style="text-align: center;">NOTE</p> <p>No 4 and No 5 may assist in pumping.</p> <p>Pump to tilt wheels</p>

No 1	Nos 2 and 3
<p>Set the three jack control levers to LOWER position</p> <p>Set the three jack control levers to RAISE</p> <p>Pull out FAST/SLOW lever to SLOW</p> <p>Level gun using spirit level (cross level = jack No 2/3 longitudinal level = jack No 1)</p> <p>Set three jack control levers to NEUTRAL</p>	<p>Set hand pump selection lever to chosen jack</p> <p>Lower gun to desired position</p> <p>Pump to level gun</p> <p>Remove hand pump lever</p> <p>Put on protective cover</p> <p>Replace hand pump lever</p> <p>Take out hand ratchets</p>

READINESS CHECK—MANUAL

No 1	Nos 2 and 3
<p>"READINESS CHECK—MANUAL"</p> <p>Prepare the following data:</p> <p> Terrain limitation</p> <p> Standby Direction</p> <p> Loading Position</p> <p>Adjust seat</p> <p>Set MOTOR/HAND levers to HAND</p>	

35 mm Twin Gun GDF 005 Drill Book

No 1	Nos 2 and 3
<p>Ensure that mechanical firing lever is at S</p> <p>Ensure that laser/trigger foot switch is covered</p> <p>Pump hydraulic pressure to 100 bar</p> <p>Ensure gas shield is in up position</p> <p>Engage collimator</p> <p>Disengage traverse lock</p> <p>"DISENGAGED"</p> <p>"LOADING POSITION"</p> <p>Indicate with an extended arm position of barrels</p> <p>Turn barrels to position manually</p> <p>"STANDBY"</p> <p>Designate standby direction</p> <p>Turn gun barrels to position manually</p> <p>Designate alarm sectors</p>	

FIRE TRIGGER CHECK—MANUAL

No 1	Nos 2 and 3
<p>"ATTENTION FIRE TRIGGER CHECK—MANUAL"</p> <p>"GUN 1 (2) FIRE TRIGGER CHECK"</p> <p>Ensure that weapons are not fed</p> <p>Check hydraulic pressure on pressure gauge reads at least 80 bar</p> <p>Set mechanical firing lever to F</p> <p>Open cover over laser/trigger foot switch</p> <p>Press down laser/trigger foot switch</p> <p>"GUN 1 (2) TRIGGERS ARE OK"</p> <p>Cover laser/trigger foot switch</p> <p>Set mechanical firing lever to S</p> <p>"TRIGGER CHECK FINISHED"</p> <p>Turn barrels to standby direction</p>	<p>Stay behind gun, outside limited zone</p>

LOADING—MANUAL

No 1	Nos 2 and 3
<p>"LOADING—MANUAL"</p> <p>"LOADING POSITION"</p> <p>Turn gun to loading position</p> <p>Ensure laser/trigger foot switch is covered</p> <p>Ensure mechanical firing lever is at S</p> <p>Engage traverse lock</p> <p>"ENGAGED"</p>	<p>Take ratchet</p> <p>Move reloader to SP and lock</p> <p>Ensure that discharge lever is in position IM</p> <p>Ensure an empty cartridge clip is in AL</p> <p>Load full cartridge clips</p> <p>Cock weapon</p> <p>Release cocking cables</p> <p>Fix hand ratchet onto shaft of ratchet drive on outside of AL</p> <p>Transport ammunition to weapon mouth with hand ratchet</p> <p>Observe transport and feeding</p> <p>Wind spring motor to stop</p> <p style="text-align: center;">WARNING</p> <p>To avoid an accident, the hand ratchet must be removed.</p> <p>Remove hand ratchet</p> <p>Add two more full cartridge clips</p>

No 1	Nos 2 and 3
<p>"LOADED AND FED"</p> <p>Ensure that no one is inside limited zone of the gun</p> <p>Disengage traverse lock</p> <p>"DISENGAGED"</p> <p>Turn barrels to standby direction</p>	<p>Report loaded and fed</p> <p>Go outside limited zone of gun</p>

STANDBY—MANUAL

No 1	Nos 2 and 3
<p>"STAND BY"</p> <p>Turn barrels to standby direction manually (elevation approximately 0-200 mil)</p> <p>Ensure that:</p> <p>TRIGGER switch on remote control unit is covered</p> <p>Mechanical firing lever is at S</p> <p>Laser/trigger foot switch is covered</p> <p>Switches on control panel:</p> <p>AMMUNITION switch on REST 3</p> <p>All other switches are in up position (ON)</p> <p>NORMAL/NARROW switch at NORMAL</p> <p>NORMAL/TEST switch at NORMAL</p> <p>WIPER switch is OFF</p> <p>RANGE switch is at LASER</p> <p>Gas shield is in up position</p>	<p>Move to rear of standby position</p>

FIRING WITH LASER

No 5	No 1	Alarm Tone
<p>"ALARM—FIVE MEDIUM"</p>	<p>Set mechanical firing lever at F</p> <p>Open laser/trigger cover</p> <p>Acquire target with collimator</p> <p>Look through optical sight and press headrest</p> <p>Keep target in centre of reticule</p> <p>Press laser/trigger foot switch (laser measuring)</p> <p>Continue tracking and follow by hand (IFF)</p>	<p>NO TONE</p> <p>MEDIUM TONE</p> <p>LONG TONE</p>
<p>"ALARM—NEW TARGET—TWO MEDIUM"</p>	<p>Turn gun in ordered direction, using manual drive</p> <p>Acquire target with collimator and proceed as described above</p> <p>Close laser/trigger cover</p> <p>Set mechanical firing lever at S</p> <p>Reload gun</p>	

No 1	No 2	No 3
Update ammunition account if possible Return to standby		

CEASE FIRING—MANUAL

No 1	Nos 2 and 3	Nos 4 and 5
"CEASE FIRING—MANUAL" Engage traverse lock "ENGAGED" Ensure mechanical firing lever is at S Ensure laser/trigger foot switch is covered Set the three jack control levers to RAISE Set FAST/SLOW control to FAST Set the three jack control levers to NEUTRAL Set wheel control lever to RAISE briefly (two pumps) Pull out	Inform Nos 4 and 5 Remove MV bases Fit muzzle brakes Lock barrels Remove hand pump lever from tool compartment Remove protective cover on hand pump Attach hand pump lever Set hand pump selection lever to the chosen jack Lift gun Pump twice	Load stores

No 1	Nos 2 and 3	Nos 4 and 5
undercarriage locking levers and turn handles through 90°		

No 1	No's 2 and 3
<p>Set wheel control lever to LOWER</p> <p>Secure undercarriage locking levers (yellow on yellow)</p> <p>Set wheel control lever to NEUTRAL</p> <p>Set the three jack control levers to DOWN</p> <p>Set the three jack control levers to NEUTRAL</p> <p>Remove hand pump lever to PSU lifting device</p> <p>Insert pump lever</p> <p>Remove locking pin</p> <p>Lift slide lever</p> <p>Pump to lift the PSU completely</p> <p>Re-insert locking pin</p> <p>Move slide lever down</p> <p>Replace pump lever</p> <p>Complete Cease Firing as in Section 2.4.3</p>	<p>Lower wheels</p> <p>Set hand pump selection lever to the chosen jack—lower gun and retract jacks completely</p> <p>Remove hand pump lever</p> <p>Put hand pump lever in tool compartment—fit protective cover</p> <p>Swing in swivel arms</p> <p>Secure safety ropes</p> <p>Bring reloaders to WP</p> <p>Release brake levers</p> <p>Release towbar</p>

**SECTION 7
QUICK ACTION**

INTRODUCTION

31. This section deals with both electrically supported and manual quick action. Quick actions are drills used to prepare the gun for imminent combat while travelling in convoy. When moving from one position to another the gun may be prepared as follows:

- a. gun not covered (environmental conditions permitting);
- b. muzzle velocity bases on;
- c. PSU lowered and running at 2200 r/min; and
- d. ammunition feeders and reloaders full.

32. The FU Commander orders the degree of preparedness.

QUICK ACTION, ELECTRICALLY SUPPORTED

No 1	Nos 2 and 3	Nos 4 and 5
"HALT—ACTION, ACTION, ACTION"		
Jump off prime mover	Jump off prime mover	Stop prime mover
Lower barrel support	Disconnect brake hoses	
Lower barrels	Disconnect towbar and lights	
Switch INSTALL switch to LVL	Ensure reloaders in SP and loaded	Drive to shelter

No 1	Nos 2 and 3	Nos 4 and 5
Start hydraulic pump Raise gun until wheels clear ground Stop hydraulic pump Set FAST/SLOW control lever to SLOW Set INSTALL switch to NORMAL Set PSU main switch to operation	Swing out and lock swivel arms Cock weapons Ensure reloaders are at WP Take cover nearby	

No 1	
All switches on control panel are up (ON) except RELOADING SYSTEM LEFT/RIGHT at OFF	
Set POWER switch to SERVO	
<div style="border: 1px solid black; padding: 5px; text-align: center;">CODER NOT CALIB</div>	
Disengage traverse lock "DISENGAGED"	
<div style="border: 1px solid black; padding: 5px; text-align: center;">MENU 1</div>	
<div style="background-color: black; color: white; padding: 5px; text-align: center; width: fit-content; margin: 0 auto;">RET</div>	
<div style="border: 1px solid black; padding: 5px; text-align: center;">DRIFT TRIM</div>	
<div style="border: 1px solid black; padding: 5px; text-align: center;">MENU 2</div>	
<div style="border: 1px solid black; padding: 5px; text-align: center;">MENU 6</div>	Select Menu 6
<div style="background-color: black; color: white; padding: 5px; text-align: center; width: fit-content; margin: 0 auto;">RET</div>	
<div style="border: 1px solid black; padding: 5px; text-align: center;">CHANGE DATA?</div>	

No 1
<div style="text-align: center; margin-bottom: 10px;"> <div style="background-color: black; color: white; padding: 5px 15px; display: inline-block;">YES</div> </div> <div style="border: 1px solid black; padding: 5px; margin-bottom: 10px; text-align: center;"> SALVOTIM ... SEC </div> <p>Enter 0.5</p> <div style="text-align: center; margin-bottom: 10px;"> <div style="background-color: black; color: white; padding: 5px 15px; display: inline-block;">RET</div> </div> <div style="text-align: center; margin-bottom: 10px;"> <div style="background-color: black; color: white; padding: 5px 15px; display: inline-block;">END</div> </div> <p>Engage target</p>

MANUAL QUICK ACTION

No 1	Nos 2 and 3	Nos 4 and 5
"HALT — ACTION, ACTION, ACTION"		Stop prime mover
Jump off prime mover	Jump off prime mover	
Remove cable rolls	Disconnect brake hoses	
	Disconnect towbar and lights	
Help remove main tarpaulin at rear	Remove main tarpaulin at front	Drive to shelter
Lower barrel support	Ensure reloaders in SP	
Lower barrels	Swing out swivel arms	
Insert wheel chock		
Climb in gunner's cabin	Cock weapons	

No 1	Nos 2 and 3	Nos 4 and 5
<p>Set FIRE/SAFE lever to FIRE</p> <p>Open laser/trigger foot switch cover</p> <p>Ensure minimum 80 bar pressure in hydraulic system</p> <p>Disengage traverse lock</p> <p>"DISENGAGE"</p> <p>Engage target using collimator and manual drive</p>	<p>Assemble ratchets and insert in AL</p> <p>Feed weapons</p> <p>Remove ratchets</p> <p>Take cover nearby</p>	

No 1	Nos 2 and 3
<p>After second burst command</p> <p>"FEED"</p> <p>Re-engage target</p>	<p>Go to gun and insert ratchets in AL</p> <p>Wind up spring motors</p> <p>Remove ratchets</p> <p>"FED"</p> <p>Take cover nearby</p>

NOTE

Continue above procedure until "ALERT STATE CHANGED". Then unload and re-establish previous travelling configuration.

SECTION 8
PREPARE GUN FOR TRAINING SIMULATOR 2

33. Prerequisites:
- a. Unload the gun.
 - b. Connect gun to the Training Simulator (TS) 2 according to the TS 2 manual *Operation and Care* (refer to C-79-207-000/MB-001).
 - c. Install the Video Presentation Unit (VPU) according to the TS 2 manual *Operation and Care* (refer to C-79-207-000/MB-001).

TS 2 Operator	No 1
<p>Select Menu 5 ALIGNMENT "PREPARE GUN 1(2)(3)(4) FOR TS 2 OPERATION"</p>	<p>"PREPARE GUN 1(2)(3)(4) FOR TS 2 OPERATION"</p> <p>Verify position of VPU (video presentation unit) main switch = ON (fully counter clockwise)</p> <p>Verify all four LEDs on VPU are on</p> <div style="text-align: center; border: 1px solid black; width: fit-content; margin: 10px auto; padding: 5px;">MENU 23</div> <div style="text-align: center; margin: 5px auto;"> <div style="background-color: black; color: white; padding: 5px 15px; display: inline-block;">RET</div> </div> <div style="text-align: center; border: 1px solid black; width: fit-content; margin: 10px auto; padding: 5px;">TRAINING MODE = 0</div> <p style="margin-top: 10px;">Enter 1</p> <div style="text-align: center; margin-top: 10px;"> <div style="background-color: black; color: white; padding: 5px 15px; display: inline-block;">RET</div> </div>

TS 2 Operator	No 1
	<div data-bbox="517 191 856 240" style="border: 1px solid black; padding: 5px; text-align: center;"> <p>CALIB LEFT?</p> </div> <p data-bbox="529 267 955 324">If the TS 2 crosshair is to the left of the reticule, press YES until aligned.</p> <div data-bbox="649 349 746 397" style="background-color: black; color: white; text-align: center; padding: 5px; margin: 10px 0;"> <p>RET</p> </div> <div data-bbox="517 410 856 459" style="border: 1px solid black; padding: 5px; text-align: center;"> <p>CALIB RIGHT?</p> </div> <p data-bbox="529 483 934 540">If the TS 2 crosshair is to the right of the reticule, press YES until aligned.</p> <div data-bbox="649 565 746 613" style="background-color: black; color: white; text-align: center; padding: 5px; margin: 10px 0;"> <p>RET</p> </div> <div data-bbox="517 630 856 678" style="border: 1px solid black; padding: 5px; text-align: center;"> <p>CALIB UP?</p> </div> <p data-bbox="529 703 944 760">If the TS 2 crosshair is higher than the reticule, press YES until aligned.</p> <div data-bbox="649 784 746 833" style="background-color: black; color: white; text-align: center; padding: 5px; margin: 10px 0;"> <p>RET</p> </div> <div data-bbox="517 846 856 894" style="border: 1px solid black; padding: 5px; text-align: center;"> <p>CALIB DOWN?</p> </div> <p data-bbox="529 919 939 976">If the TS 2 crosshair is lower than the reticule, press YES until aligned.</p> <p data-bbox="529 992 953 1081">Verify crosshairs aligned (if not aligned, press RET and start procedure at CALIB_LEFT? again).</p> <div data-bbox="649 1105 746 1154" style="background-color: black; color: white; text-align: center; padding: 5px; margin: 10px 0;"> <p>END</p> </div> <p data-bbox="494 1170 937 1398"> Switch conveyor motors OFF Set trigger switch to FIRE Set range switch to LASER Set laser sector to maximum (fully open) Set fire sector to maximum (fully open) "GUN 1(2)(3)(4) READY" </p>

CHAPTER 3
RANGE OPERATIONS

SECTION 1
RANGE FIRING

1. This part of B-GL-372-005/FP-001 *35 mm Twin Gun GDF 005 Drill Book* deals with the specific safety measures applicable when the fire unit is deployed on a firing range. Unless otherwise mentioned, the regular procedures apply. Deployment on a firing range involves additional personnel and equipment.

INTRODUCTION

2. The Range Safety Officer (RSO) is responsible to the Officer in Charge (OIC) for the safe conduct of a Gun/Skyguard live firing practice. If more than one firing point (FP) is in use, a Firing Point Officer (FPO) is required for each firing point. Each FPO is responsible to the RSO for the safe conduct at his respective FP.

3. No Skyguard or gun will be operated on the range without the proper laser attenuation filter installed. Values are: Skyguard 30 dB/Gun 20 dB. It is the RSO's responsibility to ensure that these filters are in place prior to the commencement of the practice.

4. Range practice shall be conducted in accordance with Range Standing Orders and CFP 304(3). Specific instructions for range safety are provided in these publications. Individual responsibilities of the RSO, FPO and other range personnel are described in detail in these publications.

SYSTEMATIC SEQUENCE FOR PREPARATION OF THE FIRE UNIT

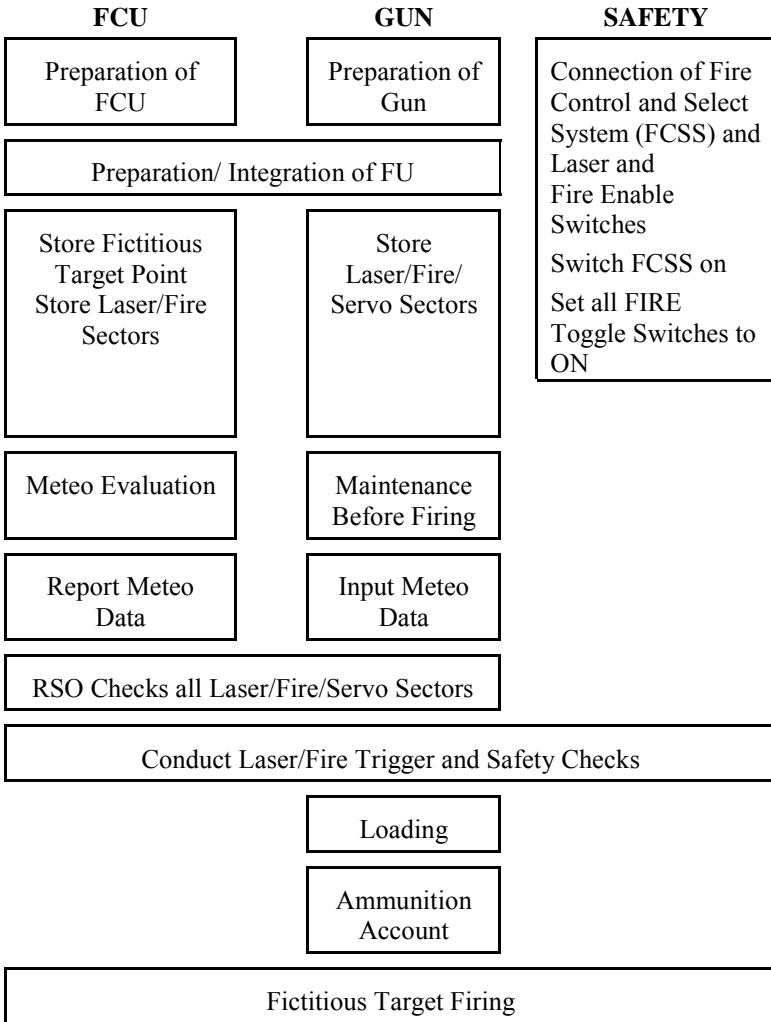

FIRE UNIT READY FOR RANGE FIRING

Figure 3-1: Systematic Sequence for Preparation of the Fire Unit

SECTION 2 DUTIES OF NUMBER 1

BEFORE FIRING

5. The Number 1 crew member on each of the gun will ensure that:
- a. the firing window and sector limitations have been set on the gun;
 - b. the safety fence and fire extinguisher are correctly in place;
 - c. the standby direction is clearly identified;
 - d. the reload position is opposite to the standby direction;
 - e. the remote control unit is properly connected to the upper mount;
 - f. the weapon top covers and weapon protective cover are properly closed and secured; and
 - g. the laser safety template is in place.

DURING FIRING

6. Number 1 will ensure that a gun crew member will remain seated on the gun during local and remote engagements. Tracking will commence when the order "FIRING RUN" is received and the target is within the range safety arcs. Laser and trigger operation will be allowed once the Weapon Safety Officer (WSO) and Laser Safety Supervisor (LSS) have ensured that all safety measures have been met. Number 1 will cease firing if:

- a. the FPO, RSO or WSO orders "CHECK FIRING";

- b. an aircraft (other than the towing aircraft) is reported in or near the range safety arcs;
- c. a vessel on an over-water range enters the range safety arcs;
- d. a target is damaged and has difficulty flying;
- e. range safety communication fails; or
- f. for any other reason deemed unsafe for firing to continue.

SECTION 3
DUTIES OF WEAPON SAFETY OFFICER/LASER SAFETY SUPERVISOR

BEFORE FIRING

7. Prior to firing each WSO, assisted by the LSS where applicable, will ensure that:
- a. the firing window and sector limitations are properly set on the gun;
 - b. the arc markers behind the gun are properly positioned;
 - c. the safety fence and fire extinguisher are correctly in place;
 - d. the laser safety place on the gun is set to blue at all times;
 - e. the laser safety plate on each gun is in place; and
 - f. the laser enable switch and the fire enable switch are correctly connected and a red flag is available.

DURING FIRING

8. During firing, each WSO (assisted by the LSS where applicable) will remain behind the gun at all times holding the laser enable switch. When the target is within the respective sector, the WSO/LSS will press the laser enable switch and the fire enable switch as applicable and will release it if:

- a. the FPO or RSO orders "CHECK FIRING";
- b. Number 1 is tracking the aircraft, if a towed sleeve is being used;
- c. an aircraft (other than the towing aircraft) is reported on or near the range safety arcs;
- d. the target is outside of the arcs or obscured by clouds;
- e. range safety communication fails;
- f. a stoppage or misfire occurs; or
- g. for any other reason deemed unsafe for firing to continue.

AFTER FIRING

9. After firing, each WSO (assisted by the LSS where applicable) will ensure that:

- a. the gun is aimed in a safe direction and that all ammunition has been removed from the weapon;
- b. the laser enable switch and fire enable switch are unlocked; and
- c. the safety fence remains in place until the barrels have been locked.

10. Once completed, the WSO will report to the FPO "WEAPONS CLEAR".

FIRE CONTROL AND SELECT SYSTEM

11. The Fire Control and Select System (FCSS) gives the RSO complete control to "ENABLE" or "DISABLE" every laser or fire signal on the range. The activation of the power switch will force "CHECK FIRING" for the whole range in a matter of seconds. Each laser or fire signal can be handled individually.

12. The FCSS is installed and connected by a qualified Range Equipment Operator (REO).

13. The fire enable switch and the laser enable switch operated by the WSO and LSS are part of the FCSS.

COMMUNICATION AND INTERCOM SYSTEM

14. The Communication and Intercom System (CIS) provides the RSO with all necessary communication links required to control the FP.

15. Communication links available are:

- a. one way communication (listening) to all connected fire units;
- b. two way communication between CIS and selected FCUs and guns;
- c. loudspeakers for announcements to all personnel on the firing point(s); and
- d. an override intercom station (voice request) for range safety.

16. The CIS is installed and connected by a qualified REO.

VIDEO EVALUATION SYSTEM

17. The Video Evaluation System (VES) is used primarily to evaluate the live ammunition firing results of the gun and the Skyguard operators against live targets. A secondary role is to provide the RSO with real time information about the target currently tracked by the Skyguard and guns. The RSO will only enable firing (using the FCSS) if the correct target is being tracked by the Skyguard and guns.

18. The VES is installed, connected and operated by a qualified REO.

SECTION 4 SAFETY SECTORS

LASER SECTOR

19. Use of the laser is permitted within the laser sector (see Figure 3-2). The laser sector is set using Menu 3. The sector is always larger than that of the fire sector.

FIRE SECTOR

20. Firing is only permitted within the fire sector (see Figure 3-2), allowing a safety margin of 100 mils for deviations of shell trajectory. The fire sector is set using Menu 4.

SERVO SECTOR

21. The servo sector is designed to restrict the electrical movement of the gun in elevation and traverse. It is set and activated using Menu 10 once the guns are loaded.

SAFETY SECTORS

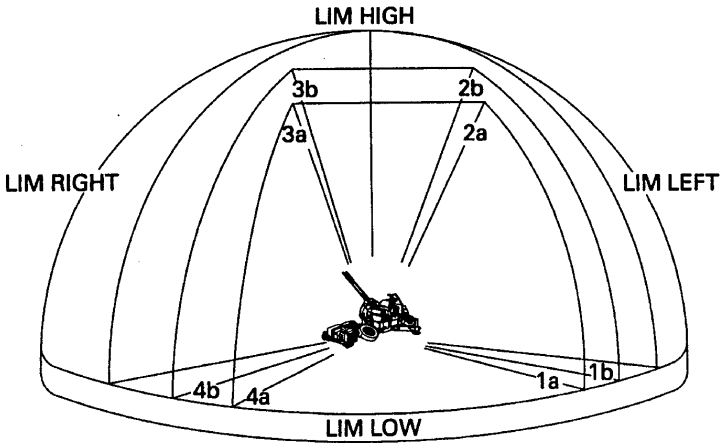

Fire Sector	1a - 2a - 3a - 4a
Laser Sector	1b - 2b - 3b - 4b
Servo Sector	LIM LEFT - LIM RIGHT - LIM HIGH - LIM LOW

Figure 3-2: Fire, Laser and Servo Sectors

SET LASER SECTOR

RSO	No 1
"SET LASER SECTOR"	<p>Set POWER switch to ON</p> <p>Set MOTOR/HAND levers to HAND</p> <div style="display: flex; align-items: center; margin-bottom: 10px;"> <div style="border: 1px solid black; padding: 5px; margin-right: 10px;">MENU 3</div> <p>Ensure that Menu 3 is selected</p> </div> <div style="text-align: center; margin-bottom: 10px;"> <div style="background-color: black; color: white; padding: 5px 15px; display: inline-block;">RET</div> </div> <div style="text-align: center; margin-bottom: 10px;"> <div style="border: 1px solid black; padding: 5px; display: inline-block;">LSECT CHECK?</div> </div> <div style="text-align: center;"> <div style="background-color: black; color: white; padding: 5px 15px; display: inline-block;">RET</div> </div>

RSO	No 1
"POINT 1: Azimuth Elevation"	<div style="border: 1px solid black; padding: 5px; margin-bottom: 10px;">LSECT PROC?</div> <div style="background-color: black; color: white; text-align: center; padding: 2px 10px; margin-bottom: 10px;">YES</div> <div style="border: 1px solid black; padding: 5px; display: inline-block; margin-right: 20px;">Azimuth Elevation 1</div> <div style="display: inline-block; vertical-align: middle;">Current position is displayed.</div> <p>"READY"</p> <p>Move gun until corresponding values appear</p>
"POINT 2: Azimuth Elevation"	<div style="border: 1px solid black; padding: 5px; margin-bottom: 10px;">Azimuth Elevation 1</div> <div style="background-color: black; color: white; text-align: center; padding: 2px 10px; margin-bottom: 10px;">RET</div> <p>"POINT 1 SET"</p> <p>Move gun until corresponding values appear</p>
"POINT 3: Azimuth Elevation"	<div style="border: 1px solid black; padding: 5px; margin-bottom: 10px;">Azimuth Elevation 2</div> <div style="background-color: black; color: white; text-align: center; padding: 2px 10px; margin-bottom: 10px;">RET</div> <p>"POINT 2 SET"</p> <p>Move gun until corresponding values appear</p>
"POINT 4: Azimuth Elevation"	<div style="border: 1px solid black; padding: 5px; margin-bottom: 10px;">Azimuth Elevation 3</div> <div style="background-color: black; color: white; text-align: center; padding: 2px 10px; margin-bottom: 10px;">RET</div> <p>"POINT 3 SET"</p> <p>Move gun until corresponding values appear</p>

RSO	No 1
	<div data-bbox="313 175 543 237" style="border: 1px solid black; padding: 2px; margin-bottom: 10px;">Azimuth Elevation 4</div> <div data-bbox="385 253 472 298" style="background-color: black; color: white; text-align: center; padding: 5px; margin-bottom: 10px;">RET</div> <p data-bbox="327 310 503 334">"POINT 4 SET"</p> <div data-bbox="385 347 472 393" style="background-color: black; color: white; text-align: center; padding: 5px; margin-bottom: 10px;">END</div> <p data-bbox="485 358 779 415">Leave menu when required points have been selected.</p> <p data-bbox="485 435 829 492">The last point stored is automatically linked to the first.</p> <div data-bbox="313 526 543 571" style="border: 1px solid black; padding: 2px; margin-bottom: 10px; width: fit-content; margin-left: auto; margin-right: auto;">MENU 4</div> <p data-bbox="327 584 599 609">"LASER SECTOR SET"</p>

SET FIRE SECTOR

RSO	No 1
"SET FIRE SECTOR"	<p data-bbox="327 821 612 846">Set POWER switch to ON</p> <p data-bbox="327 899 734 924">Set MOTOR/HAND levers to HAND</p> <div data-bbox="313 937 543 1015" style="border: 1px solid black; padding: 2px; margin-bottom: 10px; width: fit-content; margin-left: auto; margin-right: auto;">MENU 4</div> <p data-bbox="557 948 747 1005">Ensure Menu 4 is selected.</p> <div data-bbox="385 1034 472 1079" style="background-color: black; color: white; text-align: center; padding: 5px; margin-bottom: 10px;">RET</div> <div data-bbox="313 1092 543 1138" style="border: 1px solid black; padding: 2px; margin-bottom: 10px; width: fit-content; margin-left: auto; margin-right: auto;">FSECT CHECK?</div> <div data-bbox="385 1157 472 1203" style="background-color: black; color: white; text-align: center; padding: 5px; margin-bottom: 10px;">RET</div> <div data-bbox="313 1216 543 1261" style="border: 1px solid black; padding: 2px; margin-bottom: 10px; width: fit-content; margin-left: auto; margin-right: auto;">FSECT PROC?</div> <div data-bbox="385 1281 472 1326" style="background-color: black; color: white; text-align: center; padding: 5px; margin-bottom: 10px;">YES</div> <div data-bbox="313 1349 543 1427" style="border: 1px solid black; padding: 2px; margin-bottom: 10px; width: fit-content; margin-left: auto; margin-right: auto;">Azimuth Elevation 1</div> <p data-bbox="557 1360 758 1417">Current position is displayed</p>

RSO	No 1
<p>"POINT 1: Azimuth Elevation"</p>	<p>"READY"</p> <p>Move gun until corresponding values appear</p> <div data-bbox="421 365 650 428" style="border: 1px solid black; padding: 5px; margin: 10px auto; width: fit-content;"> Azimuth Elevation 1 </div> <div data-bbox="490 444 575 488" style="background-color: black; color: white; text-align: center; padding: 2px 10px; margin: 5px auto; width: fit-content;"> RET </div> <p>"POINT 1 SET"</p>
<p>"POINT 2: Azimuth Elevation"</p>	<p>Move gun until corresponding values appear</p> <div data-bbox="421 644 650 708" style="border: 1px solid black; padding: 5px; margin: 10px auto; width: fit-content;"> Azimuth Elevation 2 </div> <div data-bbox="490 724 575 768" style="background-color: black; color: white; text-align: center; padding: 2px 10px; margin: 5px auto; width: fit-content;"> RET </div> <p>"POINT 2 SET"</p>
<p>"POINT 3: Azimuth Elevation"</p>	<p>Move gun until corresponding values appear</p> <div data-bbox="421 937 650 1000" style="border: 1px solid black; padding: 5px; margin: 10px auto; width: fit-content;"> Azimuth Elevation 3 </div> <div data-bbox="490 1016 575 1060" style="background-color: black; color: white; text-align: center; padding: 2px 10px; margin: 5px auto; width: fit-content;"> RET </div> <p>"POINT 3 SET"</p>
<p>"POINT 4: Azimuth Elevation"</p>	<p>Move gun until corresponding values appear</p> <div data-bbox="421 1232 650 1300" style="border: 1px solid black; padding: 5px; margin: 10px auto; width: fit-content;"> Azimuth Elevation 4 </div> <div data-bbox="490 1317 575 1360" style="background-color: black; color: white; text-align: center; padding: 2px 10px; margin: 5px auto; width: fit-content;"> RET </div> <p>"POINT 4 SET"</p>

RSO	No 1
	<div style="display: flex; justify-content: space-between;"> <div style="width: 45%;"> <p style="text-align: center;">END</p> <div style="border: 1px solid black; padding: 5px; margin: 10px auto; width: 80px; text-align: center;">MENU 5</div> <p>"FIRE SECTOR SET"</p> </div> <div style="width: 50%;"> <p>Leave menu when required points have been selected.</p> <p>The last point stored is automatically linked to the first.</p> </div> </div>

SET SERVO SECTOR

NOTE	
<p>LIM - HIGH is normally maximum elevation in order to permit automatic reloading (1600 mils). To obtain the safety for the upper limit, a technician can set the Mechanical Fire Sector Limiter.</p>	
RSO	No 1
<p>"SET SERVO SECTOR"</p>	<p>Set POWER switch to ON</p> <p>Set MOTOR/HAND levers to HAND</p> <div style="display: flex; justify-content: space-between; align-items: center;"> <div style="border: 1px solid black; padding: 5px; margin: 10px auto; width: 80px; text-align: center;">MENU 10</div> <div> <p>Select Menu 10</p> </div> </div> <p style="text-align: center;">RET</p> <div style="display: flex; justify-content: space-between; align-items: center;"> <div style="border: 1px solid black; padding: 5px; margin: 10px auto; width: 80px; text-align: center;">SECT LIM MOUNT</div> <div> <p>1</p> <p>Activates servo sector.</p> </div> </div> <p style="text-align: center;">RET</p> <div style="display: flex; justify-content: space-between; align-items: center;"> <div style="border: 1px solid black; padding: 5px; margin: 10px auto; width: 80px; text-align: center;">SECT LIM CHECK?</div> <div> <p>RET</p> </div> </div>

RSO	No 1
"LEFT LIMIT: mil"	<div data-bbox="421 250 614 310" style="border: 1px solid black; padding: 2px; margin-bottom: 5px;">SECT LIM PROC?</div> <div data-bbox="492 329 575 370" style="background-color: black; color: white; text-align: center; padding: 2px; margin-bottom: 5px;">YES</div> <p data-bbox="434 383 549 407">"READY"</p> <p data-bbox="434 431 916 456">Move gun until corresponding value appears</p>
"RIGHT LIMIT: mil"	<div data-bbox="421 531 614 591" style="border: 1px solid black; padding: 2px; margin-bottom: 5px;">LIM_LEFT (Azimuth)</div> <div data-bbox="492 610 575 651" style="background-color: black; color: white; text-align: center; padding: 2px; margin-bottom: 5px;">RET</div> <p data-bbox="434 670 655 695">"LEFT LIMIT SET"</p> <p data-bbox="434 719 916 743">Move gun until corresponding value appears</p>
"LIMIT HIGH: mil"	<div data-bbox="421 816 614 876" style="border: 1px solid black; padding: 2px; margin-bottom: 5px;">LIM_RIGHT (Azimuth)</div> <div data-bbox="492 896 575 937" style="background-color: black; color: white; text-align: center; padding: 2px; margin-bottom: 5px;">RET</div> <p data-bbox="434 956 673 980">"RIGHT LIMIT SET"</p> <p data-bbox="434 1005 916 1029">Move gun until corresponding value appears</p>
"LIMIT LOW: mil"	<div data-bbox="421 1102 614 1162" style="border: 1px solid black; padding: 2px; margin-bottom: 5px;">LIM_HIGH (Elevation)</div> <div data-bbox="492 1182 575 1222" style="background-color: black; color: white; text-align: center; padding: 2px; margin-bottom: 5px;">RET</div> <p data-bbox="434 1242 658 1266">"LIMIT HIGH SET"</p> <p data-bbox="434 1291 916 1315">Move gun until corresponding value appears</p>
	<div data-bbox="421 1378 614 1438" style="border: 1px solid black; padding: 2px;">LIM_LOW (Elevation)</div>

RSO	No 1	
"CHECK POINT 3"	<div data-bbox="420 212 614 272" style="border: 1px solid black; padding: 2px; text-align: center;">Azimuth Elevation 2</div> <p data-bbox="434 285 554 310">"POINT 2"</p> <div data-bbox="490 467 575 516" style="background-color: black; color: white; text-align: center; padding: 2px; margin: 10px 0;">RET</div>	<div data-bbox="735 358 873 383" style="text-align: center;">WARNING</div> <p data-bbox="662 407 912 464">Gun will move to laser sector point 3.</p>
"CHECK POINT 4"	<div data-bbox="420 532 614 592" style="border: 1px solid black; padding: 2px; text-align: center;">Azimuth Elevation 3</div> <p data-bbox="434 623 554 647">"POINT 3"</p> <div data-bbox="490 789 575 837" style="background-color: black; color: white; text-align: center; padding: 2px; margin: 10px 0;">RET</div> <div data-bbox="420 850 614 911" style="border: 1px solid black; padding: 2px; text-align: center;">Azimuth Elevation 4</div> <p data-bbox="434 941 554 966">"POINT 4"</p> <div data-bbox="490 976 589 1057" style="background-color: black; color: white; text-align: center; padding: 2px; margin: 10px 0;">END</div> <div data-bbox="420 1105 614 1154" style="border: 1px solid black; padding: 2px; text-align: center; margin-top: 10px;">MENU 4</div>	<div data-bbox="735 675 873 699" style="text-align: center;">WARNING</div> <p data-bbox="662 724 912 781">Gun will move to laser sector point 4.</p> <p data-bbox="662 992 950 1049" style="margin-top: 100px;">Leave Menu 3 when all points have been checked.</p> <p data-bbox="434 1170 878 1195" style="text-align: center; margin-top: 10px;">"LASER SECTOR CHECK FINISHED"</p>

CHECK FIRE SECTOR

RSO	No 1
"FIRE SECTOR CHECK	<p>Set MOTOR/HAND levers to MOTOR</p> <p>Set POWER switch to SERVO</p> <div data-bbox="312 423 508 475" style="border: 1px solid black; padding: 2px; display: inline-block;">MENU 4</div> <p style="margin-left: 100px;">Ensure Menu 4 is selected</p> <div data-bbox="384 488 483 535" style="background-color: black; color: white; padding: 2px; display: inline-block; text-align: center;">RET</div> <div data-bbox="312 550 508 615" style="border: 1px solid black; padding: 2px; display: inline-block;">LSECT CHECK?</div> <div data-bbox="545 662 857 794" style="background-color: #e0e0e0; padding: 5px; margin-top: 20px;"> <p style="text-align: center;">WARNING</p> <p>Gun will move to fire sector point 1.</p> </div> <div data-bbox="384 794 483 841" style="background-color: black; color: white; padding: 2px; display: inline-block; text-align: center;">YES</div> <div data-bbox="312 855 508 920" style="border: 1px solid black; padding: 2px; display: inline-block;">Azimuth Elevation 1</div> <p style="margin-left: 20px;">"POINT 1"</p>
"CHECK POINT 2"	<div data-bbox="545 971 857 1102" style="background-color: #e0e0e0; padding: 5px; margin-top: 20px;"> <p style="text-align: center;">WARNING</p> <p>Gun will move to fire sector point 2.</p> </div> <div data-bbox="384 1102 483 1149" style="background-color: black; color: white; padding: 2px; display: inline-block; text-align: center;">RET</div> <div data-bbox="312 1164 508 1229" style="border: 1px solid black; padding: 2px; display: inline-block;">Azimuth Elevation 2</div> <p style="margin-left: 20px;">"POINT 2"</p>
"CHECK POINT 3"	<div data-bbox="545 1291 857 1421" style="background-color: #e0e0e0; padding: 5px; margin-top: 20px;"> <p style="text-align: center;">WARNING</p> <p>Gun will move to fire sector point 3.</p> </div>

RSO	No 1
<p>"CHECK POINT 4"</p>	<p style="text-align: center;">RET</p> <div style="border: 1px solid black; padding: 5px; margin: 10px auto; width: fit-content;"> <p style="text-align: center;">Azimuth Elevation 3</p> </div> <p style="text-align: center;">"POINT 3"</p> <div style="background-color: #cccccc; padding: 10px; margin: 10px auto; width: fit-content;"> <p style="text-align: center;">WARNING</p> <p style="text-align: center;">Gun will move to fire sector point 4.</p> </div> <p style="text-align: center;">RET</p> <div style="border: 1px solid black; padding: 5px; margin: 10px auto; width: fit-content;"> <p style="text-align: center;">Azimuth Elevation 4</p> </div> <p style="text-align: center;">"POINT 4"</p> <div style="background-color: black; color: white; padding: 5px; margin: 10px auto; width: fit-content;"> <p style="text-align: center;">END</p> </div> <div style="border: 1px solid black; padding: 5px; margin: 10px auto; width: fit-content;"> <p style="text-align: center;">MENU 5</p> </div> <p style="text-align: center;">"FIRE SECTOR CHECK FINISHED"</p> <p style="text-align: center;">Leave Menu 4 when all points have been checked.</p>

CHECK SERVO SECTOR

NOTE

1. Two methods are available to check the servo sector:
 - a. Check for the set value. The procedure is as for the fire sector but using MENU 10 instead of MENU 4.
 - b. The method given in this book includes a functional check of the limiters. By driving the gun into the set limiters, correct setting of the stops can be verified.

RSO	No 1
"CHECK SERVO SECTOR"	Set MOTOR/HAND levers to MOTOR Set POWER switch to SERVO "READY"
"CHECK LEFT LIMIT"	WARNING
Check limit with compass	Slew barrels to the left until stopped by sector limiter and wait.
"CHECK RIGHT LIMIT"	WARNING
	Gun will stop suddenly.

RSO	No 1
Check limit with compass	Slew barrels to the right until stopped by sector limiter and wait.
"CHECK LOWER LIMIT"	WARNING Gun will stop suddenly.
Check limit visually	Lower barrels until stopped by sector limiter and wait.
(if set) "CHECK UPPER LIMIT"	WARNING Gun will stop suddenly.
Check limit visually "SERVO SECTOR CHECK FINISHED"	Raise barrels until stopped by sector limiter and wait.

LASER/SAFETY CHECK

NOTE

1. The laser check tests the operation of the laser circuit after the safety devices have been installed.
2. The laser check must be carried out before firing commences and is ordered by the RSO.

WARNING

Prior to this check all laser attenuation filters (Gun 20 dB; Skyguard 30 dB) must be installed.

Skyguard	No 1	FCSS Operator	LSS
<p>"SKYGUARD SECTION READY FOR LASER CHECK"</p> <p>"ATTENTION LASER CHECK"</p>		<p>"ATTENTION SKYGUARD SECTION LASER CHECK LASER SELECTORS ARE ENABLED, REPORT"</p> <p>Set LASER selectors to ON</p> <p>Announce via loudspeaker</p>	

Skyguard	No 1	FCSS Operator	LSS
	<p>"GUN 1(2) LASER CHECK"</p> <p>Ensure NORMAL/ TEST lever is at NORMAL</p> <p>Ensure NORMAL/ NARROW lever is at NORMAL</p> <p>Ensure RANGE switch is at LASER</p> <p>Set POWER switch to SERVO</p> <p>Move barrels into laser sector</p> <p>Press periscope headrest with forehead</p>	<p>"ATTENTION LSS LASER CHECK"</p>	<p>When barrels point into laser sector press laser enable switch</p>

Skyguard	No 1	FCSS Operator	LSS
<p>Advise FCSS operator of result of Laser Check</p> <p>"SKYGUARD SECTION SAFETY CHECK"</p>	<p>Press TRACKING button</p> <p>Listen to the laser firing and the medium length bleeps</p> <p>Report to Skyguard</p> <p>"GUN 1(2) LASER OK (NOT OK)"</p>	<p>If Laser Check was OK</p> <p>Set toggle switches LASER to OFF</p> <p>"SAFETY CHECK, LASER SELECTORS ARE DISABLED"</p> <p>Announce via loudspeaker</p> <p>"SAFETY CHECK"</p>	

Skyguard	No 1	FCSS Operator	LSS
<p>Advise FCSS operator of result of Safety Check</p> <p>"LASER AND SAFETY CHECK FINISHED"</p>	<p>"GUN 1(2) SAFETY CHECK"</p> <p>Press periscope headrest with forehead</p> <p>Press TRACKING button</p> <p>Listen to the laser and the short length beeps</p> <p>Report to Skyguard</p> <p>"GUN 1(2) LASER OK (NOT OK)"</p>	<p>If Safety Check was OK "LASER AND SAFETY CHECK FINISHED"</p>	

Skyguard	No 1	FCSS Operator	LSS
	"GUN 1(2) LASER AND SAFETY CHECK FINISHED" Point barrels to standby direction	Announce via loudspeaker "LASER AND SAFETY CHECK FINISHED"	Release laser enable switch

FIRE TRIGGER/SAFETY CHECK

NOTE			
The fire trigger check tests the operation of the trigger circuit after safety devices have been installed. The fire trigger check must be carried out before any ammunition is loaded and is ordered by the RSO.			
Skyguard	No 1	FCSS Operator	LSS
"FIRE UNIT READY FOR FIRE TRIGGER CHECK"		"ATTENTION FIRE UNIT FIRE TRIGGER CHECK FIRE SELECTORS AT ENABLED, REPORT"	

Skyguard	No 1	FCSS Operator	LSS
<p>"ATTENTION FIRE TRIGGER CHECK</p> <p>Press ALARM GUN once</p>	<p>"GUN 1(2) FIRE TRIGGER CHECK"</p> <p>Set AMMUNITI ON switches to REST 3</p> <p>Set Conveyor motor switches to ON</p> <p>Set trigger switch on remote control unit to F</p> <p>Report to Skyguard</p> <p>"GUN 1(2) READY"</p>	<p>Set FIRE selectors to ON</p> <p>Announce via loudspeaker</p> <p>"ATTENTION WSO FIRE TRIGGER CHECK"</p>	
<p>WARNING</p> <p>Gun will move to fixed point</p>			

Skyguard	No 1	FCSS Operator	LSS
<p>"ATTENTION 3, 2, 1 FIRE"</p> <p>Press READY TO FIRE</p> <p>Press ALARM GUN twice</p>	<p>When alarm tone sounds once, switch LOCAL/ REMOTE switch to REMOTE</p> <p>Report to Skyguard whether or not left and right trigger solenoid operated</p> <p>"GUN 1(2) TRIGGERS OK (NOT OK)"</p> <p>When alarm tone sounds twice, switch LOCAL/ REMOTE switch to LOCAL</p>		<p>After gun moves into fire sector press fire enable switch</p>

Skyguard	No 1	FCSS Operator	LSS
<p>Advise FCSS operator of result of Fire Trigger Check</p> <p>"SKYGUARD SECTION SAFETY CHECK"</p> <p>Press ALARM GUN once</p>	<p>"GUN 1(2) SAFETY CHECK"</p>	<p>If Fire Trigger Check was OK</p> <p>Set toggle switches FIRE to OFF</p> <p>"SAFETY CHECK, FIRE SELECTORS ARE DISABLED"</p> <p>Announce via loudspeaker "SAFETY CHECK"</p>	<p>When alarm sounds twice release fire enable</p>
<p align="center">WARNING</p> <p>Gun will move to fixed point</p>			

Skyguard	No 1	FCSS Operator	LSS
<p>"SAFETY CHECK 3, 2, 1 FIRE"</p> <p>Press READY TO FIRE</p> <p>Press ALARM GUN twice</p>	<p>When alarm tone sounds once, switch LOCAL/ REMOTE switch to REMOTE</p> <p>Report to Skyguard whether or not left and right trigger solenoid operated</p> <p>"GUN 1(2) TRIGGERS OK (NOT OK)"</p> <p>When alarm tone sounds twice, switch LOCAL/ REMOTE switch to LOCAL</p>		<p>After gun moves into fire sector press fire enable switch</p>

Skyguard	No 1	FCSS Operator	LSS
<p>Advise FCSS operator of result of Safety Check</p> <p>"FIRE TRIGGER AND SAFETY CHECK FINISHED"</p>	<p>"GUN 1(2) FIRE TRIGGER AND SAFETY CHECK FINISHED"</p> <p>Close trigger switch on remote control unit</p>	<p>If Safety Check was OK "FIRE TRIGGER AND SAFETY CHECK FINISHED"</p> <p>Announce via loudspeaker</p> <p>"FIRE TRIGGER AND SAFETY CHECK FINISHED"</p>	<p>When alarm sounds twice, release fire enable</p>

35 mm Twin Gun GDF 005 Drill Book

Skyguard	No 1	FCSS Operator	LSS
	Point barrels to standby direction		

**CHAPTER 4
MAINTENANCE AND CARE**

**SECTION 1
CRADLE LOCKING PROCEDURE**

No 1	No 5
<p>“LOCKING THE CRADLE”</p> <p>Pull out the cradle handle and turn it ¼ turn until the handle is in vertical position,</p> <p>Release the handle and push on it to ensure there is no gap between the cradle handle rod receptacle.</p> <p>“CRADLE LOCKED”</p> <p>Move to the front of the barrels and raise the barrels until they stop (approx 0 mils elevation); confirm barrels are locked by trying to force travels upward. If they do not go past 0 mils elevation, they are locked, and</p> <p>Maintain upward pressure and order:</p>	<p>set the bearing and elevation change over lever to manual operation,</p> <p>traverse the gun to the maintenance sector designated by the No 1,</p> <p>lock the bearing drive handle, and</p> <p>depress the barrels to their minimum elevation (approx 142 mils).</p>

No 1	No 5
<p>“LOCK THE ELEVATION DRIVE HANDLE”</p> <p>Release upward pressure on the barrels and supervises complete and prescribed maintenance.</p>	<p>Locks the elevation drive handle and reports:</p> <p>“ELEVATION DRIVE HANDLE LOCKED”</p>

SECTION 2 STRIPPING SEQUENCE

35 mm GUN

- 1 Prior preparations:—work area, barrel supports, lubricants, rags, tools/accessories box, varsol bath and benches.
- 2 Clear weapons (SAFETY PRECAUTIONS)
- 3 Release breech block
- 4 Release automatic loader springs
- 5 Swing out swivel arms & lower jacks
- 6 Place barrels in work area

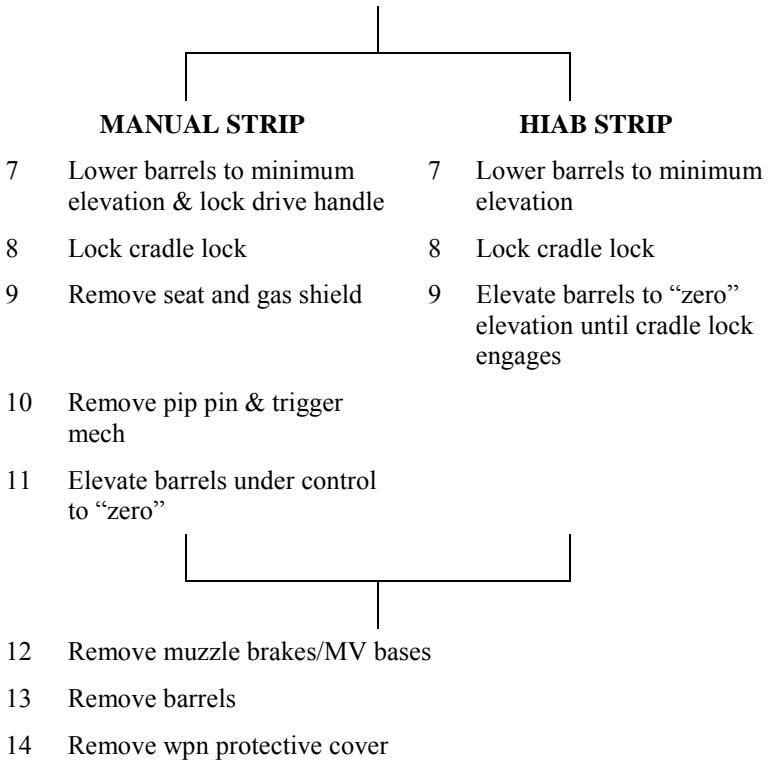

35 mm Twin Gun GDF 005 Drill Book

- Large first
- Small second

- 15 Hook up HIAB or go to step 18
- 16 Unlock receiver cover lock & slide receiver forward
- 17 Lift receivers up & under control & place on strong surface
NOTE: Trigger mech must be clear to remove
- 18 Remove top cover & slider
- 19 Remove feed plate
- 20 Remove cocking gear
- 21 Pull pip pins & spread return spring sleeve assembly
- 22 Remove breech block
- 23 Remove buffer
- 24 Pull front pip pins & remove return spring sleeve assembly
- 25 Remove the rate of fire dampening device
- 26 Remove the pistons
- 27 Remove bearing ring
- 28 Remove bearing sleeve
- 29 Unlock receiver cover lock & slide receiver forward
- 30 Remove receiver under control & and place on strong surface

BREECH BLOCK

- 1 Remove locking lugs
- 2 Remove rear
- 3 Remove pin from sliding wedge
- 4 Remove firing pin and the sliding wedge & remove from the body
- 5 Separate the firing pin from the sliding wedge
- 6 Remove securing pin from the extractor & remove rubber spring

TRIGGER MECHANISM

- 1 Remove cap & locking lever
- 2 Remove trigger mech from body
- 3 Remove locking plate from trigger mech
- 4 Remove plunger & springs from locking plate
- 5 Remove front cap and spring
- 6 Remove pin from sear body
- 7 Remove sear
- 8 Remove pin from sear & the double spring
- 9 Separate the sear from the body controlling the spring and cap
- 10 Remove locking lever from cap
- 11 Separate from the locking lever
 - 3 caps
 - 2 springs
 - 1 long spring
 - 1 short spring

SECTION 3 GUN OPERATION CHECKS

1. Gun operation checks are carried out to ensure the serviceability of the equipment.

INTRODUCTION

2. These checks may be conducted in the following conditions:
 - a. after the weapon has been assembled;
 - b. after long periods of storage; and
 - c. if time permits during Prepare for Action.

GUN OPERATION CHECK

WARNING		
Verify gun unloaded		
No 1	No 2	No 3
Standby POWER switch OFF Engage traverse lock "ENGAGED, PREPARE FOR GUN OPERATION CHECK" Set MOTOR/HAND levers to HAND Set cradle elevation to ZERO Put mechanical firing lever to S Set TRIGGER switch to OFF	Move to right of gun	Move to left of gun
	Put reloader in SP (service position) Open protective cover Cock both weapons Open weapon covers Ensure all interior parts of weapon and weapon covers are sufficiently lubricated Ensure all pins are in place Ensure that feed mechanism is assembled correctly Close and lock weapon covers Release cocking cables and check that breech block is held in position Set firing selection levers to IIII Close and lock weapon protective cover	

No 1	No 2	No 3
<p>Raise barrels to approximately 100 mil</p> <p>Check Automatic Lubrication System (ALS) pressure gauge</p> <p>Set mechanical firing lever to F</p> <p>Push laser/trigger foot switch quickly</p> <p>Set mechanical firing lever to S (safe)</p> <p>Swing barrels to ZERO</p>	<p>Listen for the sound of breech blocks hitting arresting pins</p> <p>Open weapon protective cover</p> <p>Check for injection of grease into weapons</p>	
<p>Ensure cover lock on weapon protective cover is secured</p> <p>Ensure oil level in counter-recoil is OK</p> <p>Ensure counter-recoil lever is locked</p> <p>Set MOTOR/HAND levers to MOTOR</p>	<p>Check right weapon (free of grease)</p> <p>Close and lock weapon protective cover</p> <p>Return reloaders to WP</p> <p>Ensure that muzzle brake or muzzle velocity base is properly locked</p> <p>Go outside limited zone</p>	<p>Check left weapon (free of grease)</p>

No 1	No 2	No 3
POWER switch to ON Disengage traverse lock "DISENGAGED" POWER switch to SERVO Standby position		

MECHANICAL TRIGGER AND AUTOMATIC LOADER CHECK

WARNING		
Verify Gun unloaded		
No 1	No 2	No 3
Standby "MECHANICAL TRIGGER AND AL CHECKS" Engage traverse lock "ENGAGED"	Move to right side	Move to left side
	Go inside limited zone Set reloaders to SP Ensure discharge lever is in position IM Ensure that automatic loader (AL) is empty Set firing selection levers to I (single)	
Set mechanical firing lever to F	"READY"	"READY"

No 1	No 2	No 3
Check ALS pressure gauge		
Press laser/trigger foot switch	Check trigger parallelograms, actuate trigger levers once and return to previous position	
	"SINGLE OK"	"SINGLE OK" Set firing selection levers back to IIII (series)
	"READY"	"READY"
Press laser/trigger foot switch	Ensure that trigger parallelograms remain up and that they actuate the trigger levers for the length of time that No 1 depresses laser/trigger foot switch	
	"SERIES OK"	"SERIES OK"
	Ensure that trigger parallelograms does not actuate and Report	
Set mechanical firing lever to S	"SAFE OK"	"SAFE OK"
Press laser/trigger foot switch to see if trigger mechanism is secured	Fetch hand ratchets Move AL transport systems one revolution and check teeth, pawls and general condition and smoothness of the system Return hand ratchets Move reloaders to WP Go outside limited zone	

No 1	No 2	No 3
POWER switch to ON Disengage traverse lock "DISENGAGED" POWER switch to SERVO Standby		

ELECTRICAL TRIGGER, AUTOMATIC LOADER AND RELOADER CHECK

<p style="text-align: center;">WARNING</p> Verify Gun unloaded	
No 1	No 5
"ELECTRICAL TRIGGER, AUTOMATIC LOADER AND RELOADER CHECK" Set AMMUNITION switch to REST 3 Set conveyor motor switch to ON Set TRIGGER switch to F "READY" Fire short bursts and observe whether trigger moves	Connect fire enable jumper and if required the laser enable switch

No 1	No 5
<p>Set AMMUNITION switch to REST 10 for a maximum of five seconds and check that automatic loader operates</p> <p>During test run, fire and check that trigger does not move</p> <p>"TRIGGER CHECK FINISHED"</p> <p>Set conveyor motor switch to OFF</p> <p>Set TRIGGER switch to S</p> <p>Set POWER switch to OFF</p> <p>Engage traverse lock</p> <p>"ENGAGED"</p> <p>POWER switch ON</p> <p>Reloader switches to ON</p> <p>Ensure no one is within limited zone</p> <p>Disengage traverse lock</p> <p>"DISENGAGED"</p>	 <p>Bring reloaders to SP</p> <p>Place an empty cartridge clip in AL</p> <p>Ensure that discharge lever is in position IM</p> <p>Bring reloaders to WP</p> <p>Go outside limited zone</p>

No 1	No 5
WARNING	
Gun will move	
Press reloading button Check that reloaders operate Standby	

SIGHT ALIGNMENT CHECK

NOTE															
<ol style="list-style-type: none"> 1. This check is to determine whether the sight and the gun point in the same direction. 2. The distance to the checkpoint should be at least 2.5 km with an elevation of below 100 mils. 3. If the error is greater than 2 mil, repeat the check procedure. 4. If the error is still more than 2 mil, order the maintenance personnel to inspect the gun sight system. 															
No 1															
<table style="width: 100%; border-collapse: collapse;"> <tr> <td style="border: 1px solid black; padding: 5px; width: 200px; text-align: center;">MENU 2</td> <td style="padding-left: 20px;">Select Menu 2.</td> </tr> <tr> <td colspan="2" style="text-align: center; padding: 10px 0;">RET</td> </tr> <tr> <td style="border: 1px solid black; padding: 5px; text-align: center;">ALIG CHECK?</td> <td></td> </tr> <tr> <td colspan="2" style="text-align: center; padding: 10px 0;">RET</td> </tr> <tr> <td style="border: 1px solid black; padding: 5px; text-align: center;">ALIG PROC?</td> <td></td> </tr> <tr> <td colspan="2" style="text-align: center; padding: 10px 0;">RET</td> </tr> <tr> <td style="border: 1px solid black; padding: 5px; text-align: center;">FIX1 CHECK?</td> <td></td> </tr> </table>	MENU 2	Select Menu 2.	RET		ALIG CHECK?		RET		ALIG PROC?		RET		FIX1 CHECK?		
MENU 2	Select Menu 2.														
RET															
ALIG CHECK?															
RET															
ALIG PROC?															
RET															
FIX1 CHECK?															

No 1	
<p style="text-align: center; background-color: black; color: white; padding: 2px 10px;">RET</p> <div style="border: 1px solid black; padding: 5px; margin: 5px auto; width: 80%;">FIX1 PROC?</div> <p style="text-align: center; background-color: black; color: white; padding: 2px 10px;">RET</p> <div style="border: 1px solid black; padding: 5px; margin: 5px auto; width: 80%;">FIX2 CHECK?</div> <p style="text-align: center; background-color: black; color: white; padding: 2px 10px;">YES</p> <div style="border: 1px solid black; padding: 5px; margin: 5px auto; width: 80%;">FIX2 CHECK - > RET</div> <p>Set POWER switch to ON</p> <p>Engage traverse lock</p> <p>"ENGAGED"</p>	<p>WARNING</p> <p>Gun will move to fix point 2.</p>

No 1	No 3
<p>Change MOTOR/HAND levers to HAND</p> <p>Sight accurately on fix point 2 with manual drive</p> <p>"CHECKPOINT ACQUIRED"</p>	<p>Go inside limited zone of gun</p> <p>Bring left reloader to service position</p> <p>Mount gun</p>

No 1	No 3
<p>If check is OK</p> <p>"SIGHT ALIGNMENT CHECK FINISHED"</p> <p style="text-align: center;">RET</p> <p style="text-align: center;">FIX 2 PROC ?</p> <p style="text-align: center;">END</p> <p style="text-align: center;">MENU 3</p> <p style="text-align: center;">MENU 1</p> <p style="text-align: right;">Select Menu 1.</p>	<p>Look through control optic at checkpoint</p> <p>"TRAVERSE DEVIATION MIL"</p> <p>"ELEVATION DEVIATION MIL"</p> <p>Bring reloader to waiting position</p> <p>Go outside limited zone of gun</p>

No 1
<p>If check is not OK, proceed with another checkpoint</p> <p>If still not correct, inform maintenance personnel</p> <p>Ensure that nobody is inside the limited zone</p> <p>Change the MOTOR/HAND levers to MOTOR</p> <p>Disengage traverse lock</p> <p>"DISENGAGED"</p> <p>Set POWER switch to SERVO</p> <p>"SIGHT ALIGNMENT CHECK FINISHED"</p>

SECTION 4 FAULT-FINDING/TROUBLE SHOOTING

FAULTS ON THE GUN

3. If a fault arises during the operation of the gun and the TROUBLE lamp does not illuminate or flash, the procedure is as follows:
 - a. determine the location and nature of the fault by performing the Functional Check (refer to C-79-214-000/MC-001, Functional Checklist); and
 - b. correct the fault or report the fault to the maintenance personnel.

ELECTRICAL FAULTS ON THE GUN

4. The lamp TROUBLE on the remote control unit must be off during normal operation.
5. Malfunctions that are detected by the PSU monitoring circuits, the Quick Test or the Operational Monitoring are indicated by the lamp TROUBLE.
6. The following indications are possible:
 - a. the lamp TROUBLE is illuminated; or
 - b. the lamp TROUBLE is flashing.

LAMP TROUBLE IS ILLUMINATED

7. The condition indicates a fault in the PSU.
8. In this case the procedure is as follows:

- a. Switch the gun POWER switch to position ON and lock the traverse lock.
- b. Set the ERROR/DISPL TEST switch on the PSU control box briefly to ERROR and read the error code on the display.
- c. Follow the instructions given under the error number in Section 4.2.4, PSU Error Code List.

NOTE

In a combat situation when enemy engagement is imminent, the PSU can be operated despite the presence of error codes. In this case, the main switch on the PSU control panel is put in the position EMER OPN.

LAMP TROUBLE IS FLASHING DURING NORMAL OPERATION

No 1	
TROUBLE lamp begins flashing	
MENU 9	Select Menu 9
RET	
Error Code	
Look up the first error code displayed by Menu 9 in the list of error codes in Section 4.2.3.	
END	
MENU 10	
Carry out the procedures described under that error code.	
Repeat the operation procedure that was being performed when the TROUBLE lamp started flashing.	

No 1

If the TROUBLE lamp stops flashing and is switched off, this indicates that incorrect operation causes the error. Gun operation can be resumed.

If the TROUBLE lamp continues to flash

MENU 9

Select Menu 9

RET

Error Code

Look up the first error code displayed by Menu 9 in the list of error codes in Section 4.2.3.

Record the subsystem number given under that error code.

END

MENU 10

Carry out the Functional Check as described in C-79-214-000/MC-001, Functional Checklist.

NOTE

If several error codes are displayed in Menu 9, proceed in accordance with Section 4.2.2 for each of the error codes.

LAMP TROUBLE IS FLASHING AFTER QUICK TEST (MENU 8)

No 1

MENU 9

Select Menu 9

RET

Error Code

No 1

Look up the first error code displayed by Menu 9 in the list of error codes in Section 4.2.3.

END

MENU 10

Carry out the procedures described under that error code.

After carrying out the procedures listed under the error code, repeat the Quick Test.

MENU 8

Select Menu 8.

Set NORMAL/TEST switch to TEST.

WARNING

Gun will move erratically.

RET

TEST ACTIVE

Quick Test program runs automatically.

MENU 9

Set NORMAL/TEST switch to NORMAL.

If the TROUBLE lamp stops flashing and goes out, this indicates that the fault has been corrected. Gun operation can be resumed.

If the TROUBLE lamp continues to flash

MENU 9

Ensure that Menu 9 is selected.

RET

Error Code

No 1

Look up the first error code displayed by Menu 9 in the list of error codes in Section 4.2.3.

Record the subsystem number given under that error code.

END

MENU 10

Carry out the Functional Check as described in C-79-214-000/MC-001, Functional Checklist.

NOTES

1. If several error codes are displayed in Menu 9, proceed as described in Section 4.2.2.3 for each of the error codes.
2. If the fault cannot be located and corrected using the Functional Check, call the maintenance personnel.

GUN ERROR CODES**Gun Error Codes**

- 1501** Gun does not level automatically within 15 seconds
 Set POWER switch to OFF.
 Engage traverse lock and dismount the gun.
 Set PSU NORMAL/LVL ONLY switch to LVL ONLY.
 Ensure that the FAST/SLOW control lever is at SLOW.
 Level gun using jack controls and the spirit level.
 Set PSU NORMAL/LVL ONLY switch to NORMAL.
 Mount gun, disengage traverse lock and set POWER switch to SERVO.

Functional Check subsystem number 1500

Gun Error Codes

3201 Trigger signal is interrupted by the trigger safety circuit
Ensure that:

- the fire blocking device is not activated;
- the elevation segment is not activated, the end stops in either the upper or lower positions;
- the trigger safety switch is open and that the toggle switch is in the UP position;
- the laser/trigger safety plate is showing RED (trigger and laser fire free) or BLUE, and the laser interrupter switch is connected and pressed;
- both CONVEYOR switches are ON (in the UP position);
- both AMMUNITION switches are on REST 3; and
- the Fire Sector is correctly entered in Menu 4.

Functional Check subsystem number 3200

3900 No corrective action possible—proceed directly with the Functional Check

Functional Check subsystem number 3900

3901 RIGHT AUTOMATIC RELOADER FAILED TO COMPLETE THE RELOADING SEQUENCE
Pull the automatic reloader back to the waiting position.
Ensure that:

- the feeler is completely retracted;
- the loading arms are in the correct position;
- the gun coefficients in Menu 20 are correct;
- at least one cartridge clip is in the automatic loader;
- there are no skewed cartridge clips in the automatic reloader and automatic loader; and
- the unloading lever is in position I.

Carry out the reloading sequence once again.

Gun Error Codes	
	<p>If that fails, lock the automatic reloader in the service position with safety lock and switch it OFF at the control panel.</p> <p>If possible, carry out Functional Check.</p>
	Functional Check subsystem number 3900
3902	<p>LEFT AUTOMATIC RELOADER FAILED TO COMPLETE THE RELOADING SEQUENCE</p> <p>Proceed as per error number 3901 above.</p>
	Functional Check subsystem number 3900
3903	<p>NO CARTRIDGE CLIP IN THE RIGHT AUTOMATIC LOADER</p> <p>Place an empty cartridge clip in the right automatic loader.</p>
	Functional Check subsystem number 3900
3904	<p>Right safety circuit is not closed</p> <p>Ensure that:</p> <ul style="list-style-type: none"> the automatic reloader is in the waiting position; the feeler arm is in the correct position; and the loading arms are in the correct position.
	Functional Check subsystem number 3900
3905	<p>No cartridge clip in the left automatic loader</p> <p>Place an empty cartridge clip in the left automatic loader.</p>
	Functional Check subsystem number 3900
3906	<p>Left safety circuit is not closed</p> <p>Proceed as per error number 3904 above.</p>
	Functional Check subsystem number 3900
3907	<p>No signal received from the gun drives</p> <p>Ensure that:</p>

Gun Error Codes	
	<p>the elevation motor is switched ON; and</p> <p>the gun has been calibrated in traverse and elevation.</p>
	Functional Check subsystem number 3900
5100	No corrective action possible—proceed directly with the Functional Check
	Functional Check subsystem number 5100
5101	<p>Gun drives not activated</p> <p>Switch the traverse and elevation drives ON at the control panel.</p> <p>Ensure that:</p> <p style="padding-left: 40px;">Menu 10 shows SECT_LIM MOUNT = 0;</p> <p style="padding-left: 40px;">the traverse lock is disengaged;</p> <p style="padding-left: 40px;">the MOTOR/HAND levers are on MOTOR; and</p> <p style="padding-left: 40px;">the POWER switch is on SERVO.</p>
	Functional Check subsystem number 5100
5102	<p>Error in the PSU Mains 2 power supply</p> <p>Ensure that:</p> <p style="padding-left: 40px;">no error indications are on the PSU display;</p> <p style="padding-left: 40px;">the Mains 2 power cable (marked blue) is correctly attached; and</p> <p style="padding-left: 40px;">the circuit breakers on the PSU are depressed.</p>
	Functional Check subsystem number 5100
5103	<p>Error in the gun trailer Mains 1 power supply</p> <p>Ensure that:</p> <p style="padding-left: 40px;">all circuit breakers on the connector box (F1-F12) are depressed; and</p> <p style="padding-left: 40px;">after pressing the connector box circuit breakers, verify that the circuit breakers on the PSU are depressed (F1-F3).</p>
	Functional Check subsystem number 5100

Gun Error Codes	
5104	<p>Error in the upper mount Mains 1 power supply</p> <p>Ensure that:</p> <ul style="list-style-type: none"> all circuit breakers on the control panel are depressed (F1-F4); both automatic loader circuit breakers Q2 on the automatic loader support are depressed; and both circuit breakers Q1 on the automatic reloader distribution box are depressed.
	Functional Check subsystem number 5100
5105	<p>Gun drive safety circuit is open</p> <p>Ensure that:</p> <ul style="list-style-type: none"> the MOTOR/HAND levers are on MOTOR; the cradle lock is in the UNLOCKED position; the traverse lock is DISENGAGED; the PSU is in the operation position (lowered); the barrel support is lowered; and the automatic reloaders are in the waiting position or they are locked in the service position and switched OFF.
	Functional Check subsystem number 5100
5106	<p>Gun drives are not calibrated</p> <p>Calibrate gun drives either electrically or manually.</p>
	Functional Check subsystem number 5100
5107	<p>Excess temperature in the gun drives</p> <p>Allow the gun drives to cool.</p>
	Functional Check subsystem number 5100
5108	<p>No corrective action possible – proceed directly with the Functional Check</p>
	Functional Check subsystem number 5100

Gun Error Codes	
5300	<p>No corrective action possible – proceed directly with the Functional Check</p> <p>Functional Check subsystem number 5300</p>
5350	<p>No corrective action possible – proceed directly with the Functional Check</p> <p>Functional Check subsystem number 5350</p>
5351	<p>Laser excess temperature</p> <p>During the Quick Test ensure that the NORMAL/TEST switch is set to TEST.</p> <p>Allow the laser transmitter to cool.</p> <p>Functional Check subsystem number 5350</p>
5600	<p>No signals from MV measuring bases</p> <p>Ensure that:</p> <ul style="list-style-type: none"> MV measuring bases are correctly connected; and cable guide jib is connected to the cradle. <p>Functional Check subsystem number 5600</p>
5601	<p>No corrective action possible —report the fault to the maintenance personnel</p> <p>Functional Check subsystem number 5600</p>
5700	<p>No corrective action possible — proceed directly with the Functional Check</p> <p>Functional Check subsystem number 5700</p>
5701	<p>Overheating in the electronics cabinet</p> <p>Check that the fan is working (cooling air can be felt at the rear of the cabinet).</p> <p>Functional Check subsystem number 5700</p>
5900	<p>No corrective action possible — proceed directly with the Functional Check</p> <p>Functional Check subsystem number 5900</p>

Gun Error Codes	
5901	<p>No data received from the FCU</p> <p>Ensure that:</p> <ul style="list-style-type: none"> the LOCAL/REMOTE switch is set to LOCAL; or the switch is set to REMOTE and the data cables are attached at both ends. <p>If still unsuccessful, check the data transmission from the FCU before carrying out Functional Check.</p>
Functional Check subsystem number 5900	

POWER SUPPLY UNIT ERROR CODES

Power Supply Unit Error Codes	
00	<p>Fuel reserve at lowest limit</p> <p>Connect refuelling device.</p> <p>Connect full fuel can to refuelling device.</p> <p>Momentarily switch FUEL switch to REFUELLING or switch PSU main switch to OFF.</p> <p>Pour fuel directly from fuel can into internal tank.</p>
01	<p>Oil pressure too low or too high</p> <p>Check whether [09 Oil level low] is also displayed.</p> <p>Remove PSU hood.</p> <p>Check oil level and refill if level is too low.</p> <p>If oil level is too high, drain off excess oil via sump drain screw.</p> <p>No corrective action possible—proceed directly with the Functional Check</p>
Functional Check subsystem number 7000	
02	<p>Oil temperature too high</p>

Power Supply Unit Error Codes	
	<p>Check that the air outlet cover is rolled up.</p> <p>Set GEN switch to OFF</p> <p>Check that the cover is placed over the frame and air inlet and outlet are unobstructed.</p>
	Functional Check subsystem number 7000
03	<p>Water temperature too high</p> <p>Proceed as per code 02.</p>
04	<p>WAIT</p> <p>Appears when PSU main switch has been set to OPERATION and the engine has not yet reached working temperature.</p> <p>Wait until D (= operation) is displayed before starting to operate the gun.</p>
05	<p>Air cleaner (air flow to engine restricted)</p> <p>Remove cover and check that air flow is unobstructed and that the air filter is not blocked.</p> <p>No corrective action possible—proceed directly with the Functional Check</p>
	Functional Check subsystem number 7000
06	<p>Alternator</p> <p>No corrective action possible—proceed directly with the Functional Check</p>
	Functional Check subsystem number 7000
07	<p>Generator</p> <p>No corrective action possible—proceed directly with the Functional Check</p>
	Functional Check subsystem number 7000
08	<p>Mains 1 fault</p> <p>No corrective action possible—proceed directly with the Functional Check</p>

Power Supply Unit Error Codes	
	Functional Check subsystem number 7000
09	<p>Oil level low</p> <p>Check that the gun is leveled properly.</p> <p>Switch off PSU.</p> <p>Remove cover and check oil level.</p> <p>Refill if necessary (distance between MIN and MAX marks on dipstick corresponds to 1 litre of engine oil).</p>
71	<p>Frequency too high (governor needs adjustment)</p> <p>No corrective action possible—proceed directly with the Functional Check</p>
	Functional Check subsystem number 7000
72	<p>Frequency too low (governor needs adjustment)</p> <p>No corrective action possible—proceed directly with the Functional Check</p>
	Functional Check subsystem number 7000
73	<p>Overvoltage (voltage regulator needs adjustment)</p> <p>No corrective action possible—proceed directly with the Functional Check</p>
	Functional Check subsystem number 7000
74	<p>Undervoltage (voltage regulator needs adjustment)</p> <p>No corrective action possible – proceed directly with the Functional Check</p>
	Functional Check subsystem number 7000
75	Generator temperature too high

Power Supply Unit Error Codes
<p>Set PSU main switch to STANDBY. Allow PSU to cool at idling speed.</p> <p>Check that the air outlet cover is rolled up.</p> <p>Check that the cover is placed over the frame and air flow inlet and outlet are free of obstruction.</p> <p>No corrective action possible – proceed directly with the Functional Check</p>
<p>Functional Check subsystem number 7000</p>

MISFIRES/STOPPAGES ELECTRICAL

No 1
<p>Fire the weapon. If nothing happens, cancel Menu 9 and re-fire the weapon.</p> <p>If the weapon still does not fire check the following:</p> <ul style="list-style-type: none">TRIGGER switch on remote control unit is ON;laser/trigger interrupters are activated;Range Safety Officer (RSO) has Fire Control and Select Systems (FCSS) interrupters on;weapon is in the fire sector;ensure weapon is in TRACKING mode; andAMMUNITION switches are at correct REST position. <p>If all the above conditions are met and the gun is hot (i.e., the gun has been fired) No 1 will place the gun in the LOAD position, report the misfire to the RSO, set the POWER switch to OFF, and switch the CONVEYOR MOTORS to OFF.</p> <p>The gun position is to be evacuated for a period of 20 minutes before any corrective measures are taken.</p>

MISFIRES/STOPPAGES MECHANICAL

No 1
<p>Press laser/trigger foot switch.</p> <p>If nothing happens:</p> <p>Ensure mechanical firing lever is at F position.</p> <p>If not, place at F and fire.</p> <p>If at F position, determine whether the weapon is hot or cold.</p> <p>The same drills apply as for electrical misfires and stoppages, except:</p> <p style="padding-left: 40px;">apply the manual hand brake on the elevation and traverse drive handles after placing the gun in the LOAD position; and</p> <p style="padding-left: 40px;">ensure mechanical firing levers are at S.</p>

SECTION 5 PREVENTIVE MAINTENANCE

INTRODUCTION

9. All preventive maintenance tasks to be performed by the operator and the maintainer are listed in the Preventive Maintenance Schedule (PMS)—refer to C-79-214-000/NY-001.
10. The PMS lists the tasks in accordance with their periodicity and prescribes by whom the work must be done.
11. To carry out some of the more complex tasks, special instructions are necessary. The instructions of the operator tasks are contained in the Operator Maintenance Instructions (OMI) manual—refer to C-79-214-000/ML-001.

12. The Detachment Commander is responsible for ensuring that all preventive maintenance is carried out and that anything outside the detachment's capability is reported to the FCU Commander.

MATERIALS CHECK

13. The detachment is responsible for the stores on the gun and for the contents of the cases.

14. The materials check must be carried out periodically, at least once a month. For further information use the PMS--refer to C-79-214-000/NY-001.

15. Any damage or loss must be reported to the maintenance personnel so that the item can be repaired or replaced.

16. The materials check is to be carried out according to the inventory list WW 804 180, which is contained in the special pocket mounted in the cover of the accessory case.

NOTE

When ordering parts, always state the part name and NATO Stock Number.

17. Gun grease, G-403, is identified by contractor part number C 2752 550 and/or MIL-G-10924D (9150-21-891-3609). High pressure grease, Molycote G-N Paste, is identified by contractor part number W 2753 058 (9150-01-047-9668).

18. The NATO stock numbers for lens paper and cleaning solution (used to clean Gun King sight and screen) are:

Lens Paper	6640-21-859-5588
Cleaning Solution	6850-21-570-1220

LIST OF ABBREVIATIONS

°C	Centigrade
2IC	The Detachment Second in Command
AL	Automatic Loader
ALIGN	Alignment
ALS	Automatic Lubrication System
AMM_RELO	Ammunition Reload
Ammo	Ammunition
AZ	Azimuth (bearing)
BAL_NO	Ballistic Number
bar	Barometric
CALIB	Calibrated
CIS	Communication and Intercom System
DEG	Degrees
DSPL	Display
EL	Elevation
END	End (key)

35 mm Twin Gun GDF 005 Drill Book

F	Fire
F_RATE L	Firing Rate Left
F_RATE R	Firing Rate Right
FCSS	Fire Control and Select System
FCU	Fire Control Unit
FID	Failure Identification
Fired L	Fired Left
Fired R	Fired Right
FP	Firing Point
FPO	Firing Point Officer
FSECT	Firing Sector
FU	Fire Unit
GEN	Generator
I/O	Input/Output
IFF	Identification Friend/Foe
ILLUM	Illumination
LIM	Limit
LSS	Laser Safety Supervisor
LVL	Levelling

M	Measure
M/S	Metre per second
MAG	Magazine
MBAR	Millibars
MIL	Milliradians
NSN	NATO Stock Number
NTDR	Near Term Digital Radio
OMI	Operator Maintenance Instructions
ORIENT	Orientation
PMS	Preventive Maintenance Schedule
POS	Position
PRESS	Pressure
PROC	Procedure
psi	Pounds per Square Inch
PSU	Power Supply Unit
RAN	Range
RD	Round
RELO	Reload
RES	Reserve
RET	Return (key)

35 mm Twin Gun GDF 005 Drill Book

RSO	Range Safety Officer
S	Safe
SALVOTIM	Salvo Time
sec	Second
SECT	Sector
SOP	Standard Operating Procedure
SP	Service Position
T	Trigger
TBD	To be Determined
TS	Training Simulator
TV	Television
VES	Video Evaluation System
VO	Muzzle Velocity Value
VPU	Video Presentation Unit
W	Warning
WINDIR	Wind Direction
WP	Waiting Position